

CDD6-36SXXE3C(N)2 Series DC/DC Converter



Typical Features

- ◆ Wide input voltage range (4:1), Output power 6W
- ◆ Transfer efficiency up to 88%
- ◆ With remote control shutdown function
- ◆ Continuous short circuit protection, Self-furbish
- ◆ No overshoot when switching on and off
- ◆ Isolation voltage: 1500VDC
- ◆ Operating Temperature range: -40°C~+85°C



Test Condition: Unless otherwise specified, data in the datasheet should be tested under the conditions of inputting nominal voltage, pure resistance rated load and Ta=25°C.

Application Filed

CDD6-XXSXXE3C2 is a newly designed DIP packed, 6W output power, wide input range 4:1, low stand-by power consumption, isolated regulated single output DC-DC converter, could be widely used for industrial control, instrument, communication, power electricity, thins of Internet field.

Typical Product List

Part No.	Input Voltage Range (Vdc)		Output Voltage/Current (Vo/Io)		Input Current (mA) Nominal Voltage		Max. Capacitive Load uF	Ripple & Noise mVp-p	Efficiency (%)@output full load, input nominal	
	Nominal	Range	Voltage (Vdc)	Current (mA) MAX./Min.	Full load Typ.	No load Typ.			Min	Typ
CDD6-36S05E3(N)2	48	18-75	5	1200/0	149	10	1500	100	82	84
CDD6-36S12E3(N)2	48	18-75	12	500/0	144	10	680	100	85	87
CDD6-36S15E3(N)2	48	18-75	15	400/0	142	10	330	100	86	88
CDD6-36S24E3(N)2	48	18-75	24	250/0	144	10	220	100	85	87

Note: 1: The maximum capacitive load refers to the capacitance capacity that the output is allowed to connect when the power supply is fully loaded. If the capacity is exceeded, the power supply may not be able to start;

2: C is with control pins, and N is without control pins;

3: Due to space Limited, the above is only a partial list of products, if you need products other than the list, please contact our sales department.

Input Specifications

Item	Working Condition	Min.	Nominal	Max.	Unit
Starting voltage	Input 18-75v	--	--	18	VDC
Input undervoltage protection	Input 18-75v	--	13	--	VDC
Standby power consumption	0.25W (TYP)				
Input Filter	Π filter				
CTRL	The module is turned on, CTRL is left floating or connected to a high level (3.3VDC-9VDC)				
	Module shutdown CTRL connected to low level (0-0.8VDC)				
	Input current at shutdown			2mA (TYP)	

Output Specifications

Output Voltage Accuracy	Full voltage range	≤±2.0%	
Voltage Regulation	Nominal load, full voltage range	Vo	≤±0.5%
Load Regulation	10% ~ 100% nominal load	Vo	≤±1.0%
Ripple & Noise*	Nominal load, nominal voltage ≤100mVp-p (20MHz bandwidth)	≤100mVp-p (20MHz bandwidth)	
Temperature Drift Coefficient	100% FULL LOAD	±0.03%/°C	
Dynamic Response	25% nominal load step change	ΔVo/Δt	±5.0%/0.5ms(Typ.)
Output Over voltage protection	110%~160%Vo		
Output Over load protection	120%~220%		
Output Short Circuit Protection	Continuous, Self-recovery		
Turn-on delay time	Typ:10ms		
Output Turn-on Overshoot Voltage	≤10%Vo		

Note: Ripple & noise test adopts twisted pair method, see Design and Application Circuit Reference for details.

General Specification

Switching Frequency	Typical	300KHz
Operating Temperature	Refer to temperature derating curves	-40°C ~ +85°C
Storage Temperature		-55°C ~ +125°C
Max Case Temperature	Within Operating Curve	+105°C
Relative Humidity	No condensing	5%~95%
Case Material	-	Aluminum metal shell
Pin Soldering Temperature	The solder joint is 1.5mm away from the shell, 10 seconds	300°C MAX
Isolation Voltage	Input to Output	Input-output 1500Vdc ≤ 0.5mA / 1min
Meantime Between Failure	MIL-HDBK-217F@25°C	2X10 ⁵ Hrs
Product Weight	-	22g (Typ.)

EMC Characteristics

Total Items		Sub Items	Test Standard	Class
EMC	EMI	CE	CISPR22/EN55032	CLASS B (see recommended circuit photo②)
		RE	CISPR22/EN55032	CLASS B (see recommended circuit photo②)
	EMS	RS	IEC/EN61000-4-3	10V/m Perf.Criteria B (see recommended circuit photo②)
		CS	IEC/EN61000-4-6	3Vr.m.s Perf.Criteria B (see recommended circuit photo②)
		ESD	IEC/EN61000-4-2	Contact ±4KV Perf.Criteria B
		Surge	IEC/EN61000-4-5	±2KV Perf.Criteria B (see recommended circuit photo①)
		EFT	IEC/EN61000-4-4	±2KV Perf.Criteria B (see recommended circuit photo①)
		Voltage dips, dips and short interruptions immunity	IEC/EN61000-4-11	0%~70% Perf.Criteria B

Product Characteristic Curve

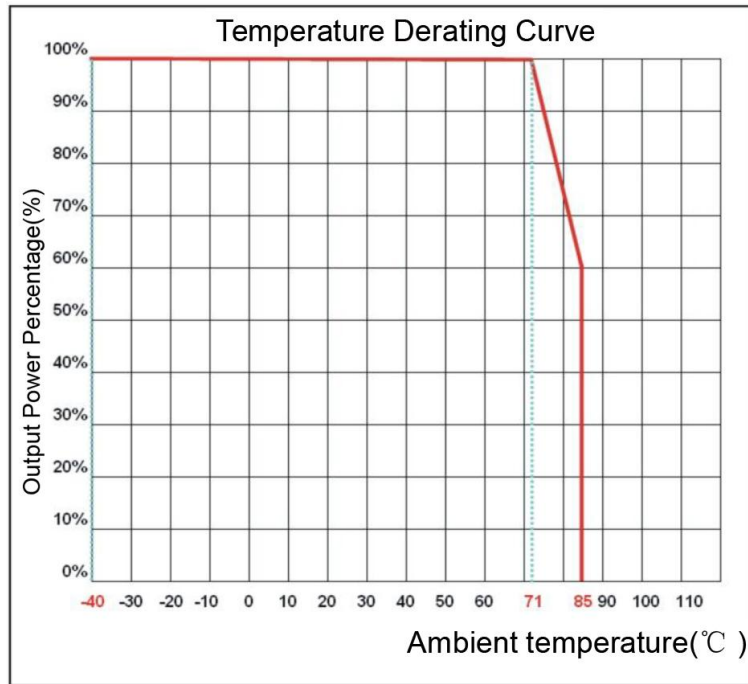

Packing Dimension

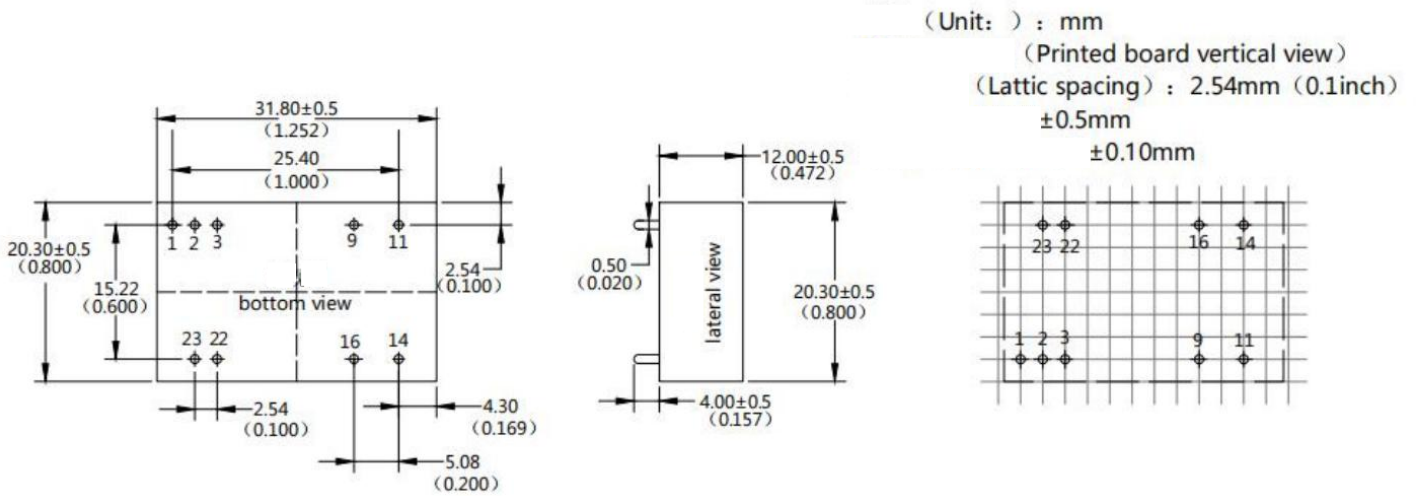

Packing Code	L x W x H	
E3	31.80 × 20.30 × 12mm	1.252 × 0.800 × 0.472inch

Pin-out

Pins Function	1	2	3	9	11	14	16	22	23
CDD6-XXSXXE3C2	Ctrl	-Vin	-Vin	NP	NC	+Vo	GND	+Vin	+Vin
CDD6-XXSXXE3N2	NP	-Vin	-Vin	NP	NC	+Vo	GND	+Vin	+Vin

Note: If the definition of pin is not in accordance with the model selection manual, please refer to the label on actual item.

Ripple & Noise Test: (Twisted Pair Method 20MHZ bandwidth)

Test Method:

a. 12# twisted pair to connect, Oscilloscope bandwidth set as 20MHz, 100M bandwidth probe, terminated with 0.1uF polypropylene capacitor and 10uF high frequency low resistance electrolytic capacitor in parallel, oscilloscope set as Sample pattern.

b. Input terminal connect to power supply, output terminal connect to electronic load through jig plate, Use 30cm±2cm sampling line, Power line selected from corresponding diameter wire with insulation according to the flow of output current.

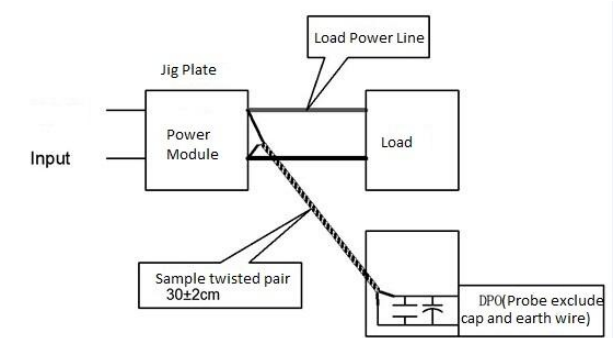

Design and Application Reference

Recommended circuit

① DC/DC test circuit

Normal recommended capacitors: C0: 47-100uF; C1:470uF.

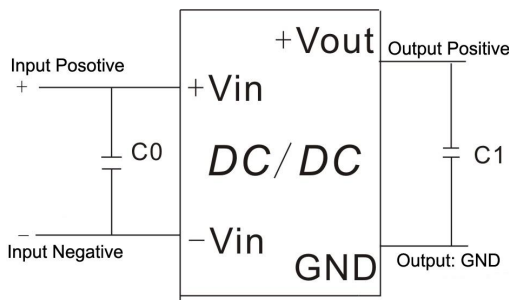

② Input reflecting ripple current test circuit:

Capacitor C choose low ESR ones, withstand voltage value should be bigger than max input voltage;

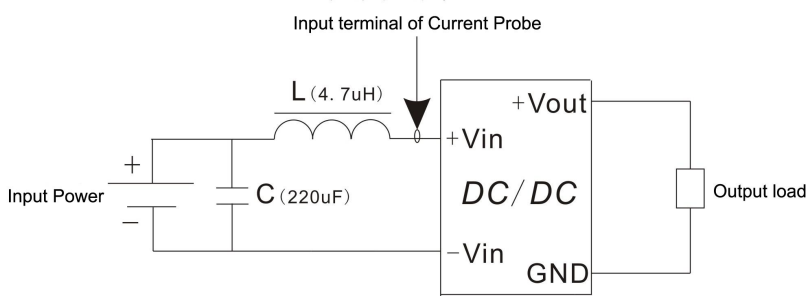

EMC External Recommended Circuit:

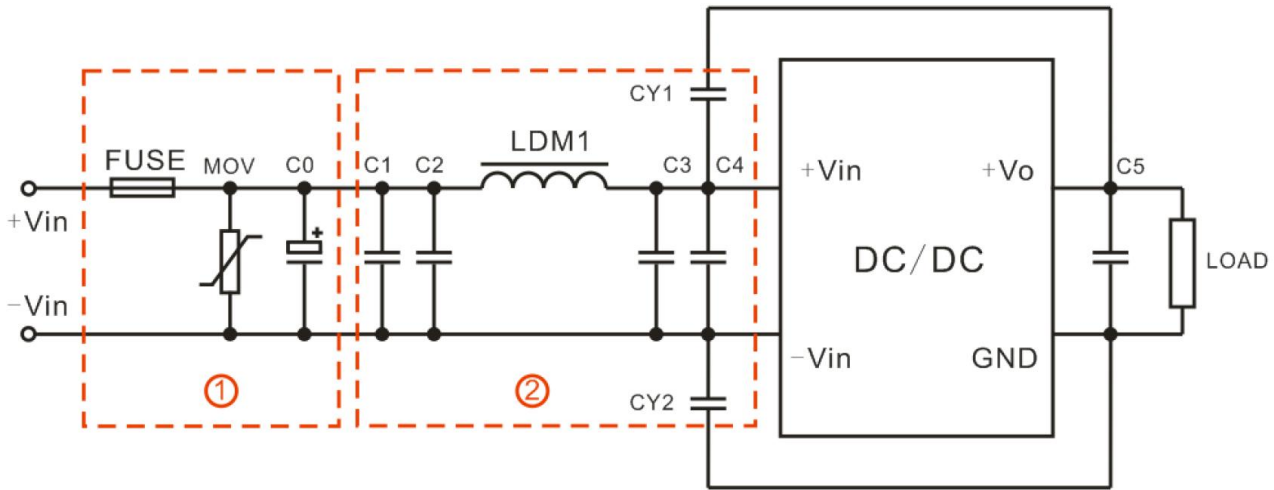

Recommended Spec:

Component	18V Input	36V Input
FUSE	According to customer's request	
MOV	14D560K	14D101K
C0	470uF/50V	470uF/50V
C1,C2,C3,C4,C5	10uF/50V	10uF/50V
LDM1	10uH	10uH
CY1,CY2	1nF/2000V	

Note:

1. The product should be used under the specification range, otherwise it will cause permanent damage to it.
2. If the product worked beyond the load range or below the minimum load, we cannot ensure that the performance of product is in accordance with all the indexes in this manual;
3. Unless otherwise specified, data in this datasheet should be tested under conditions of $T_a=25^{\circ}\text{C}$, humidity<75% when inputting nominal voltage and outputting rated load(pure resistance load);
4. All index testing methods in this datasheet are based on our Company's corporate standards
5. The performance indexes of the product models listed in this manual are as above, but some indexes of non-standard model products will exceed the above-mentioned requirements, and please directly contact our technician for specific information;
6. We can provide customized product service;
7. The product specification may be changed at any time without prior notice.