

Product Typical Features

- ◆ Wide input voltage range (4:1), Output Power 12W
- ◆ Transfer Efficiency up to 87%
- ◆ Stand-by Power Consumption as low as 0.02W
- ◆ Output super-fast start up
- ◆ Continuous Short Circuit protection, Self-recovery
- ◆ Input under voltage, output over voltage, short circuit, over current protection
- ◆ Switching Frequency 250KHz
- ◆ Isolation Voltage 2150VAC
- ◆ Operating Temperature:-40°C~+85°C
- ◆ Good EMI performance
- ◆ International standard pin-out



Test Condition: Unless otherwise specified, data in the datasheet should be tested under the conditions of inputting nominal voltage, pure resistance rated load and Ta=25°C.

Application Field

CFD12-XXSXXA3(C)4 is a newly designed DIP 1X1 packed, 12W output power, ultra wide input range 4:1, low stand-by power consumption, isolated regulated output DC-DC converter, could be widely used for industrial control, instrument, communication, power electricity, internet of things field.

Typical Product List

Part No	Input Voltage Range (VDC)		Output Voltage/Current (Vo/Io)		Input Current (mA) Nominal Voltage		Max. Capacitive Load uF	Ripple & Noise		Efficiency (%)@output full load, input nominal voltage	
	Nominal	Range	Voltage (VDC)	Current (mA) MAX./Min.	Full load typ.	No Load typ.		mVp-p		Min	Typ
								Typ.	Max.		
CFD12-18S3V3A3(C)4	24	9-36	3.3	2400/0	423	1	5000	50	100	75	78
CFD12-18S05A3(C)4	24	9-36	5	2000/0	514	1	2000	50	100	78	81
CFD12-18S09A3(C)4	24	9-36	9	1333/0	595	1	1000	50	100	81	84
CFD12-18S12A3(C)4	24	9-36	12	1000/0	595	1	1000	50	100	84	86
CFD12-18S15A3(C)4	24	9-36	15	800/0	588	1	800	50	100	82	85
CFD12-18S24A3(C)4	24	9-36	24	500/0	581	1	600	50	100	85	87
CFD12-36S3V3A3(C)4	48	18-75	3.3	2400/0	211	1	5000	50	100	75	78

CFD12-36S05A3(C)4	48	18-75	5	2000/0	257	1	2000	50	100	78	81
CFD12-36S09A3(C)4	48	18-75	9	1333/0	297	1	1000	50	100	81	84
CFD12-36S12A3(C)4	48	18-75	12	1000/0	297	1	1000	50	100	84	86
CFD12-36S15A3(C)4	48	18-75	15	800/0	294	1	800	50	100	84	86
CFD12-36S24A3(C)4	48	18-75	24	500/0	290	1	600	50	100	85	87

- Suffix "-T" is for chassis mounting, "-TS" suffix is for DIN-Rail mounting, DIN-Rail width is: 35mm;
- Max capacitive load is, when the power supply is fully loaded, the max capacity could be connected to output, if exceed, the power supply cannot start-up;
- To reduce no load power consumption and improve efficiency of light-load, IC will be flitter frequency under no-load and light-load operating, output cannot be no load, at least with 10% load or above 470uF high frequency low resistance electrolytic capacitor, otherwise the output ripple will rise;
- Suffix "C" is with Ctrl function, Suffix "N" is without Ctrl function.

Input Specification

Stand-by Consumption	0.05 W(TYP)		
Input Filter	π filter		
Input Under-Voltage Protection	5~9VDC@CFD12-18SXXA3 Input		
	11~18VDC@CFD12-36SXXA3 Input		
CTRL*	Module turn-on	CTRL suspended or TTL high level (2.5-12VDC)	
	Module turn-off	CTRL connect to GND or low level (0-1.2VDC)	
	Input current when switched off	5mA (TYP)	

Note: *The voltage of CTRL pin is relative to GND pin.

Output Specification

Output Voltage Accuracy	Full voltage full load	Vo	$\pm 2.0\%$
Voltage Regulation	Nominal load, full voltage rang	Vo	$\pm 0.5\%$
Load Regulation	10% ~ 100% nominal load	Vo	$\pm 1.0\%$
Ripple & Noise	Nominal load, nominal voltage Twisted Pair Method, 20M Hz bandwidth;	$\leq 15\%$ load,	5%Vo mVp-p typ
		$\geq 15\%$ load,	50mVp-p typ, 100mVp-p
Output Over-voltage Protection	120%~200%Vo		
Output Over-load Protection	110%~220%Io		
Output Short circuit Protection	Continuous, Self-recovery		

Dynamic Response	25% nominal load step change	$\Delta V_o/\Delta t$	$\leq 6\%/500\mu s$
Output Voltage Regulation	Not Available		
Turn-on delay time	Typical	250ms	
Output Turn-on Overshoot Voltage			$\leq 10\%V_o$

General Specification

Switching Frequency	Typical	250KHz
Operating Temperature	Refer to Temperature Derating Curve	-40°C ~ +85°C
Storage Temperature		-55°C ~ +125°C
Max Case Temperature	Within Operating Curve	+105°C
Relative Humidity	No condensing	5%~95%
Case Material		Aluminum Metal Case
Cooling Method		Free air convection
Isolation Voltage	Input to Output	2150Vac \leq 5mA / 1min
Meantime Between Failure	MIL-HDBK-217F@25°C	2X10 ⁵ Hrs
Product Weight	Average	18g

EMC Characteristics

Total Items	Sub Items	Test Standard	Class	
EMC	EMI	CE	CISPR22/EN55032 CLASS B (see recommended circuit photo ②)	
		RE	CISPR22/EN55032 CLASS B (see recommended circuit photo ②)	
	EMS	RS	IEC/EN61000-4-3	10V/m Perf.Criteria B (see recommended circuit photo 2)
		CS	IEC/EN61000-4-6	3Vr.m.s Perf.Criteria B (see recommended circuit photo 2)
		ESD	IEC/EN61000-4-2	Contact $\pm 4KV$ Perf.Criteria B
		Surge	IEC/EN61000-4-5	$\pm 2KV$ Perf.Criteria B (see recommended circuit photo 1)
		EFT	IEC/EN61000-4-4	$\pm 2KV$ Perf.Criteria B (see recommended circuit photo 1)
		Voltage dips, short interruptions and voltage variations immunity	IEC/EN61000-4-11	0%~70% Perf.Criteria B

A3 Packing Dimension

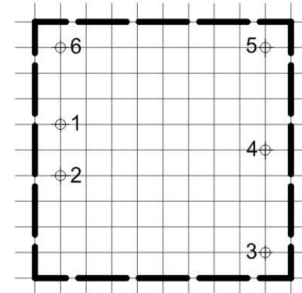
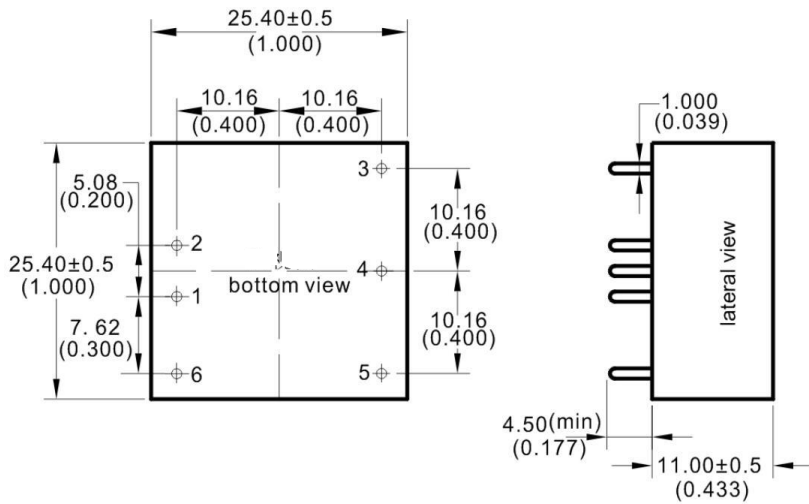

Unit: mm
 Print board vertical view
 Grid: 2.54mm(0.1inch)
 General tolerance: ± 0.25 mm
 Pin section tolerances: ± 0.10 mm

A3-H Packing Dimension

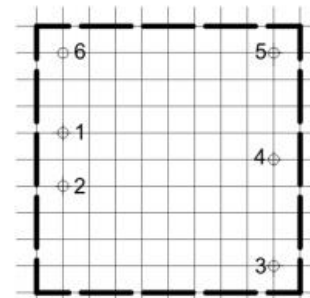
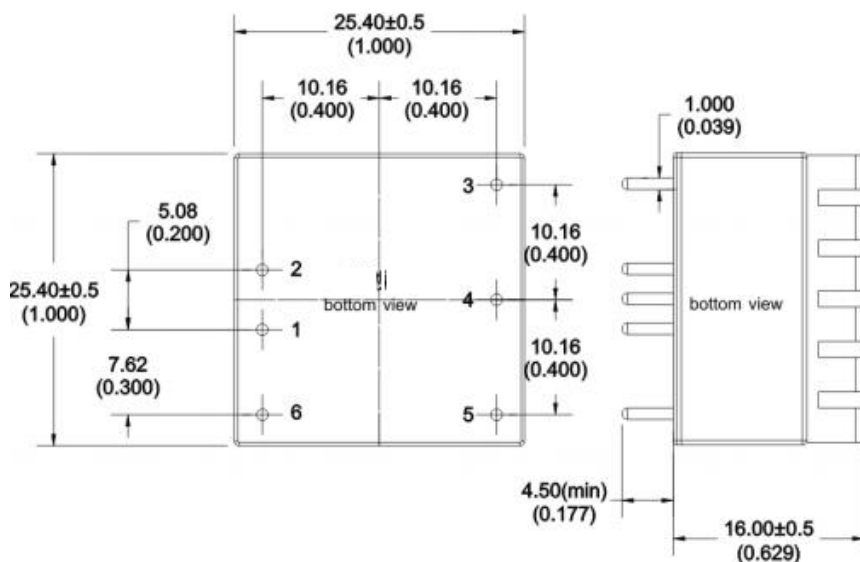

Unit: mm
 Print board vertical view
 Grid: 2.54mm(0.1inch)
 General tolerance: ± 0.25 mm
 Pin section tolerances: ± 0.10 mm

A3-T Packing Dimension

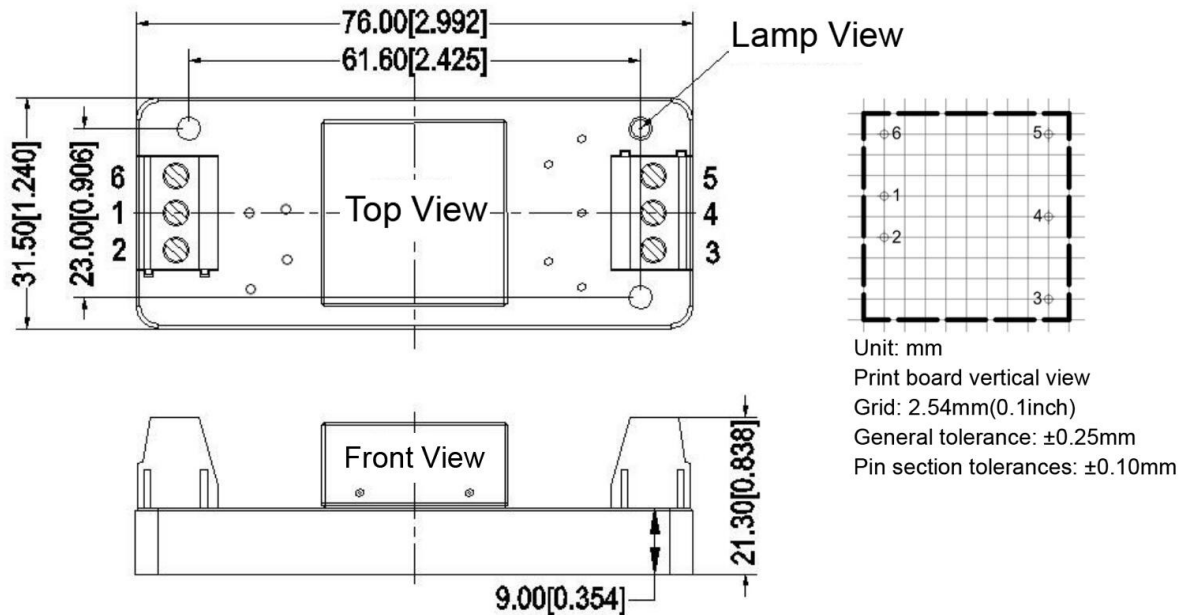

A3-TS Packing Dimension

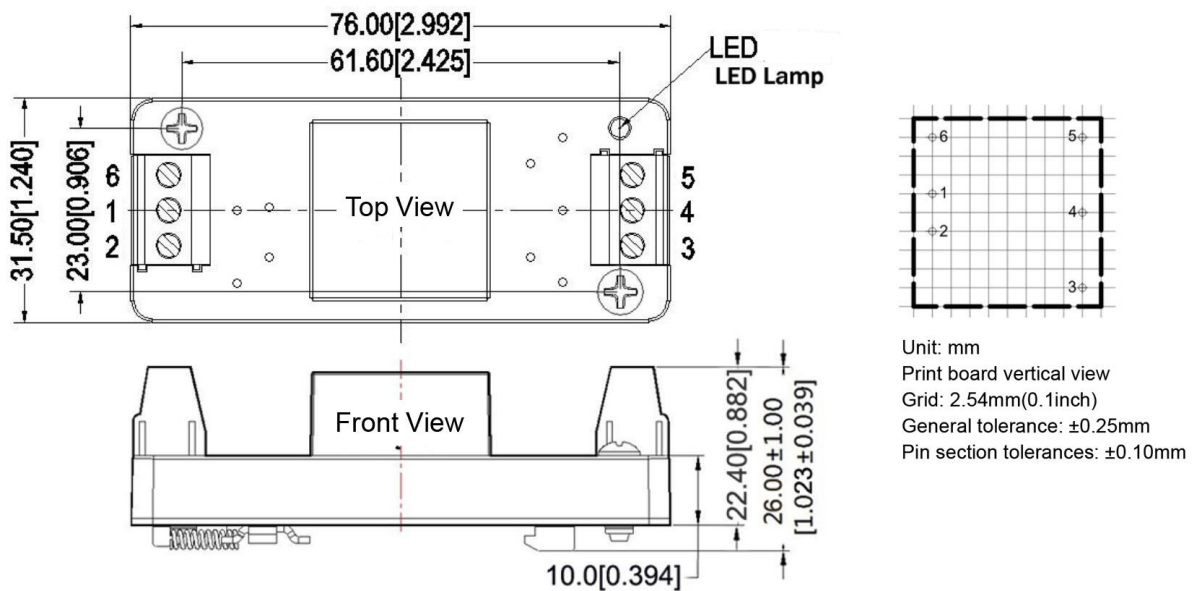

Packing Code	L x W x H	
A3	25.4X 25.4X11 mm	1X1 X0.433inch
A3-T	76X31.5X21.3mm	2.99X1.24X0.838inch
A3-H	25.4X25.4X16mm	1X1 X0.629inch

Pin-out

Single (S)	1	2	3	4	5	6
	-Vin	+Vin	+Vout	NP	GND	CTRL
Positive and negative dual (D)	1	2	3	4	5	6
	-Vin	+Vin	+Vout	COM	-Vout	CTRL

Ripple & Noise Test: (Twisted Pair Method 20MHz bandwidth)

Test Method:

a. 12# twisted pair to connect, Oscilloscope bandwidth set as 20MHz, 100M bandwidth probe, terminated with 0.1uF polypropylene capacitor and 10uF high frequency low resistance electrolytic capacitor in parallel, oscilloscope set as Sample pattern.

b. Input terminal connect to power supply, output terminal connect to electronic load through jig plate, Use $30\text{cm} \pm 2\text{cm}$ sampling line, Power line selected from corresponding diameter wire with insulation according to the flow of output current.

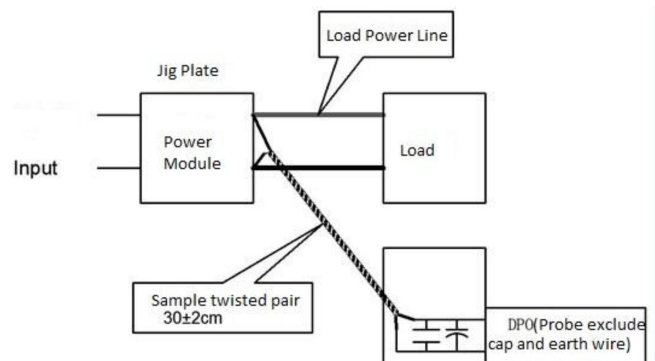

Application Reference:

1. The recommended minimum load is 10% or above 470uF high frequency low resistance electrolytic capacitor, or output ripple will rise;
2. Recommend the unbalance loads of dual output to be $\leq \pm 5\%$;
3. The maximum capacitive load is tested under pure resistance and full load condition;
4. Our company could provide whole power supply solution, or customized made items; Due to space limitation, please contact our team for more information.

Product Characteristic Curve

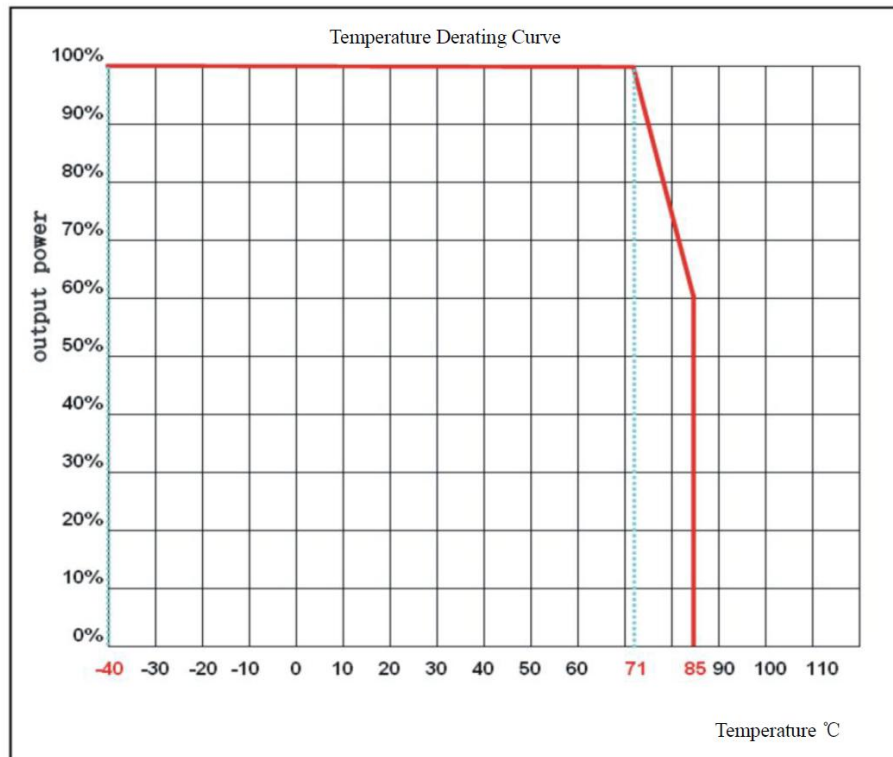

Design Application

Recommended circuit

1. DC/DC test circuit:

Normal recommended capacitors: C0: 47-100uF; C1: 470uF.

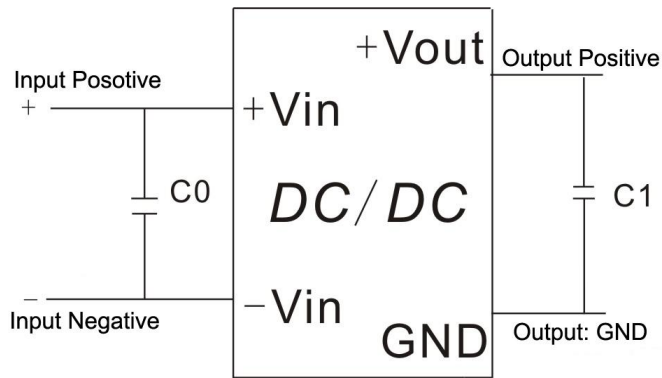

2. Input reflecting ripple current test circuit:

Capacitor C choose low ESR ones, withstand voltage value should be bigger than max input voltage;

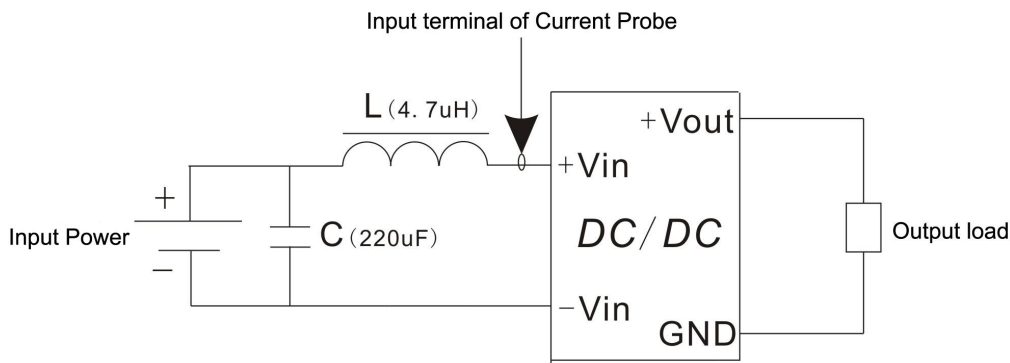

3. EMC external recommended circuit:

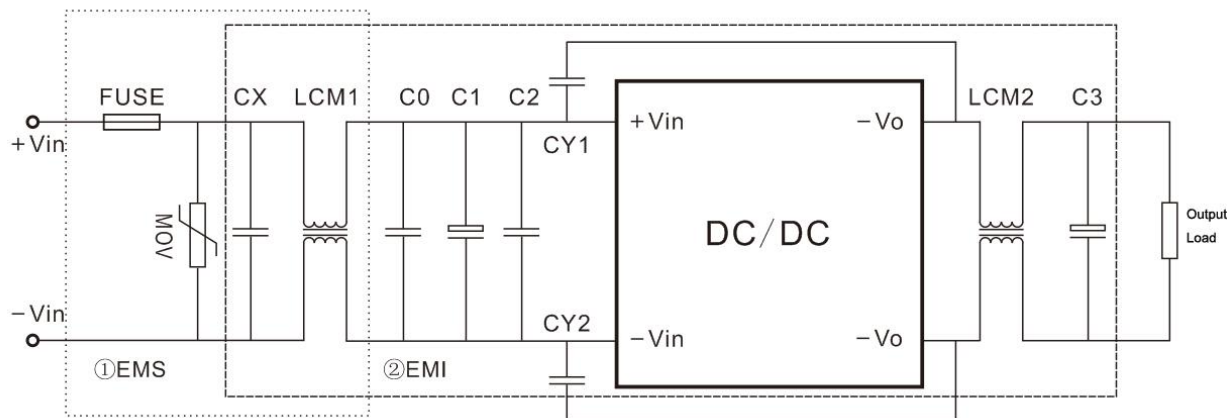

Recommended Spec:

Component	CFD12-18SXXA3 Input	CFD12-36SXXA3 Input
FUSE	According to customer's request	
MOV	14D560K	14D101K
CX	0.47uF	0.47uF
LCM1	5mH	5mH
C0	1uF/100V	1uF/100V
C1	220uF/100V	220uF/100V
C2	1uF/100V	1uF/100V
LCM2	30uH	30uH
C3	47uF/50V	47uF/50V
CY1,CY2	1nF/2000V	

Note:

1. The product should be used under the specification range, otherwise it will cause permanent damage to it.
2. If the product worked beyond the load range or below the minimum load, we cannot ensure that the performance of product is in accordance with all the indexes in this manual;
3. Unless otherwise specified, data in this datasheet should be tested under conditions of $T_a=25^{\circ}\text{C}$, humidity<75% when inputting nominal voltage and outputting rated load(pure resistance load);
4. All index testing methods in this datasheet are based on our Company' s corporate standards
- 5.The performance indexes of the product models listed in this manual are as above, but some indexes of non-standard model products will exceed the above-mentioned requirements, and please directly contact our technician for specific information;
6. We can provide customized product service;
7. The product specification may be changed at any time without prior notice.