

Product Typical Features
◆ Wide Input Voltage Range(4:1), Output power 12W
◆ Transfer Efficiency up to 90%
◆ Stand-by Power Consumption as low as 0.2W
◆ Output super-fast start up
◆ Continuous Short Circuit protection, Self-recovery
◆ Input under voltage, output over voltage, short circuit, over current protection
◆ Switching Frequency 300KHz
◆ Isolation Voltage: 5000VDC
◆ Operating temperature: -40°C~+85°C
◆ Good EMI performance
◆ International standard pin-out



Testing Condition: Unless otherwise specified, data in the datasheet should be tested under the conditions of inputting nominal voltage, pure resistance rated load and Ta=25°C.

Application Field

CFD20-XXSXXB2C5 is a newly designed DIP 2X1 packed, 20W output power, ultra wide input range 4:1, low stand-by power consumption, isolated regulated output DC-DC converter, could be widely used for industrial control, instrument, communication, power electricity, internet and etc.

Typical Product List

Part No.	Input Voltage Range(VDC)		Output Voltage/ Current (Vo/Io)		Input Current (mA) (Nominal Voltage)		Max Capacitive Load uF	Ripple & Noise		Efficiency of output full load (%)	
	Nominal	Range	Voltage (VDC)	Current (mA) MAX./Min.	Full Load typ.	No Load typ.		mVp-p		Min	Typ
								Typ.	Max.		
CFD20-18S3V3B2C5	24	9-36	3.3	4000/0	650	50	8000	50	100	82	84
CFD20-18S05B2C5	24	9-36	5	4000/0	946	50	5000	50	100	85	87
CFD20-18S09B2C5	24	9-36	9	2222/0	936	30	2000	50	100	87	89
CFD20-18S12B2C5	24	9-36	12	1667/0	936	7	1000	50	100	87	89
CFD20-18S15B2C5	24	9-36	15	1333/0	930	7	800	50	100	87	89
CFD20-18S24B2C5	24	9-36	24	833/0	926	2	500	50	100	88	90
CFD20-36S3V3B2C5	48	18-75	3.3	4000/0	320	25	8000	50	100	84	86
CFD20-36S05B2C5	48	18-75	5	4000/0	473	30	5000	50	100	85	87
CFD20-36S09B2C5	48	18-75	9	2222/0	468	15	2000	50	100	87	89
CFD20-36S12B2C5	48	18-75	12	1667/0	468	5	1000	50	100	85	87
CFD20-36S15B2C5	48	18-75	15	1333/0	470	5	800	50	100	86	88
CFD20-36S24B2C5	48	18-75	24	833/0	465	5	500	50	100	87	89

- 1、 -T suffix for chassis mounting, -TS suffix for DIN-Rail mounting, DIN-Rail width is: 35mm;
- 2、 Max capacitive load is, when the power supply is fully loaded, the max capacity could be connected to output, if exceed, the power supply cannot start-up;
- 3、 To reduce no load power consumption and improve efficiency of light-load, IC will be flitter frequency under no-load and light-load operating, output cannot be no load, at least with 10% load or above 330uF high frequency low resistance electrolytic capacitor, otherwise the output ripple will rise;

Input Specification

Stand-by Consumption	0.2 W(TYP)		
Input Filter	π Filter		
Input Under-Voltage Protection	5~9VDC@ CFD20-18SXXB2C5 Input		
	11~18VDC@ CFD20-36SXXB2C5 Input		
CTRL*	Module turn-on	CTRL suspended or TTL high level (2.5-12VDC)	
	Module turn-off	CTRL connect to GND or low level (0-1.2VDC)	
	Input current when switched off	5mA (TYP)	

Note: The voltage of *CTRL pin is relative to GND pin

Output Specification

Output Voltage Accuracy	Full voltage full load	Vo	$\pm 2.0\%$
Voltage Regulation	Nominal load, full voltage range	Vo	$\pm 0.5\%$
Load Regulation	10% ~ 100% nominal load	Vo	$\pm 1.0\%$
Ripple & Noise	Nominal load, nominal voltage Twisted Pair Method, 20M Hz bandwidth;	$\leq 15\%$ Load,	5%Vo mVp-p typ
		$\geq 15\%$ Load,	50mVp-p typ, 100mVp-p max
Output Over-voltage Protection	110%~200%Vo		
Output Over load Protection	110%~220%Io		
Output Short circuit Protection	Continuous, Self-recovery		
Dynamic Response	25% nominal load step change $\Delta Vo/\Delta t$	3.3V、5V Output	$\pm 5\%$ typ , $\pm 8\%$ max /500us
		Other output	$\pm 3\%$ typ , $\pm 5\%$ max /500us
Output Voltage Regulation	Not Available		
Turn on Delay time	Typical	150ms	
Output Turn-on Overshoot Voltage			$\leq 10\%Vo$

Note: * Ripple & Noise is tested under the Twisted Pair test method

General Specification

Switching Frequency	Typical	300KHz
Operating Temperature	Refer to Temperature Derating Curve	-40°C ~ +85°C
Storage Temperature		-55°C ~ +125°C
Max Case Temperature	Within Operating Curve	+105°C
Relative Humidity	No condensing	5%~95%
Case Material		Black flame-retardant heat-resistant Plastic
Cooling Method		Free air convection
Isolation Voltage	Input to Output	5000Vdc ≤ 0.5mA / 1min
Meantime Between Failure	MIL-HDBK-217F@25°C	2X10 ⁵ Hrs
Weight	Average	30g

EMC Compatible Characteristic

Total Item		Sub Item	Test Standard	Class
EMC	EMI	CE	CISPR22/EN55032	CLASS B (see recommended circuit photo ②)
		RE	CISPR22/EN55032	CLASS B (see recommended circuit photo ②)
	EMS	RS	IEC/EN61000-4-3	10V/m Perf.Criteria B (see recommended circuit photo 2)
		CS	IEC/EN61000-4-6	3Vr.m.s Perf.Criteria B (see recommended circuit photo 2)
		ESD	IEC/EN61000-4-2	Contact ±4KV Perf.Criteria B
		Surge	IEC/EN61000-4-5	±2KV Perf.Criteria B (see recommended circuit photo 1)
		EFT	IEC/EN61000-4-4	±2KV Perf.Criteria B (see recommended circuit photo 1)
		Voltage dips short interruptions and voltage variations immunity	IEC/EN61000-4-11	0%~70% Perf.Criteria B

B2C5 Packing Dimension

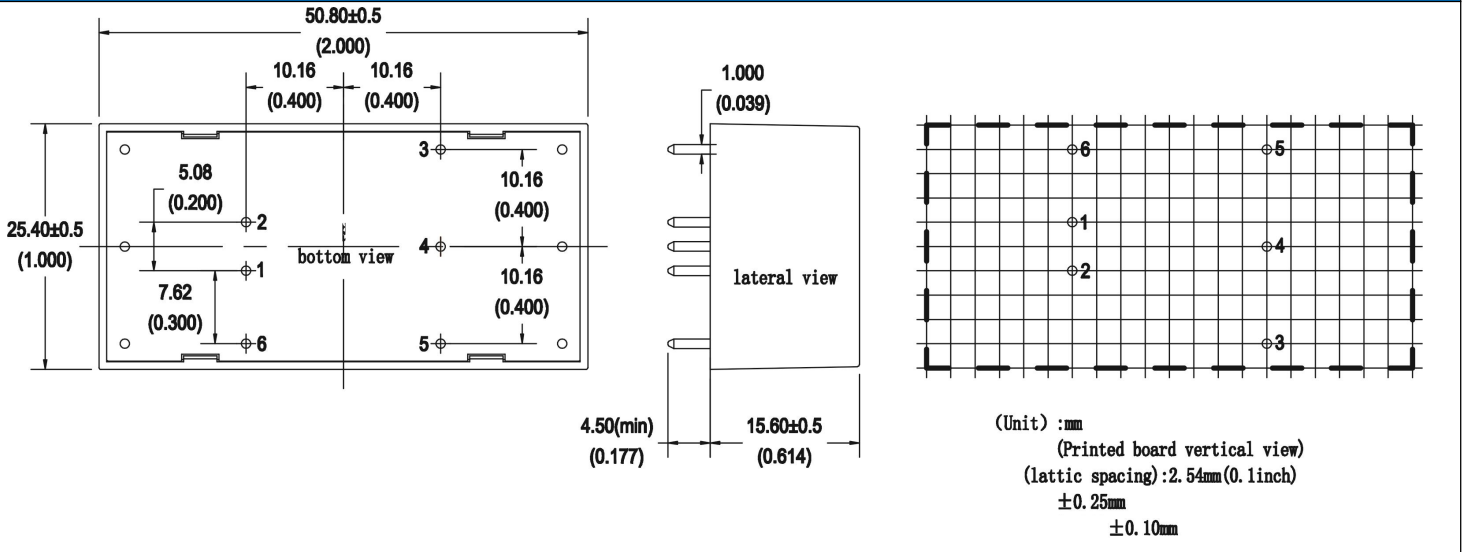

Prototype product No.	L x W x H					
B	50.8X 25.4X15.6 mm					
Single(S)	1	2	3	4	5	6
	-Vin	+Vin	+Vout	NP	GND	CTRL

Note: If the definition of pin is not in accordance with the model selection manual, please refer to the label on actual item.

Ripple & Noise Test: (Twisted Pair Method 20MHz bandwidth)

Test Method:

- 12# twisted pair to connect, Oscilloscope bandwidth set as 20MHz, 100M bandwidth probe, terminated with 0.1uF polypropylene capacitor and 10uF high frequency low resistance electrolytic capacitor in parallel, oscilloscope set as Sample pattern.
- Input terminal connect to power supply, output terminal connect to electronic load through jig plate, Use $30\text{cm} \pm 2\text{cm}$ sampling line, Power line selected from corresponding diameter wire with insulation according to the flow of output current.

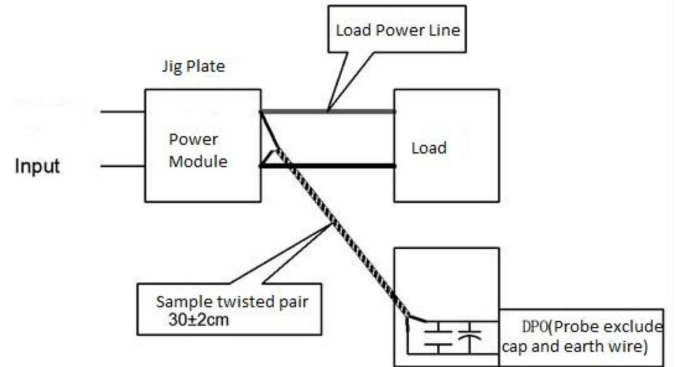

Application Reference:

- The recommended minimum load is 10% or above 470uF high frequency low resistance electrolytic capacitor, or output ripple will rise;
- Recommend the unbalance loads of dual output to be $\leq \pm 5\%$;
- The maximum capacitive load is tested under pure resistance and full load condition;
- Our company could provide whole power supply solution, or customized made items; Due to space limitation, please contact our team for more information.

Product Characteristic Curve

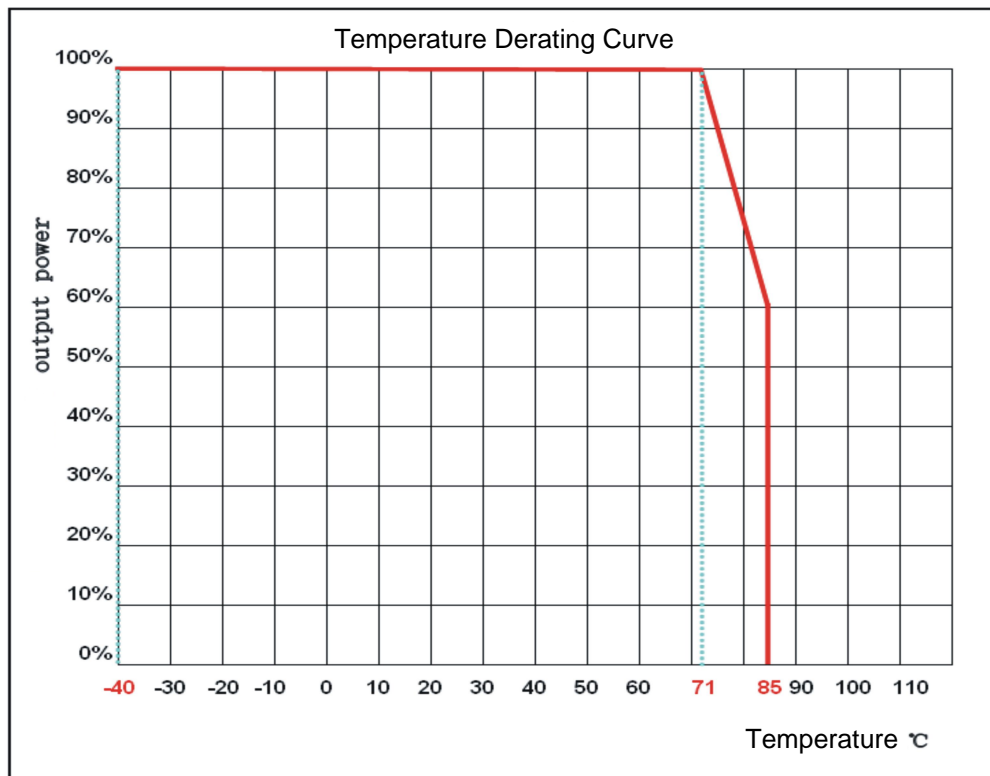

Recommended Circuit

1. DC/DC test circuit

General recommended capacitors C0: 47-100uF; C1: 330uF.

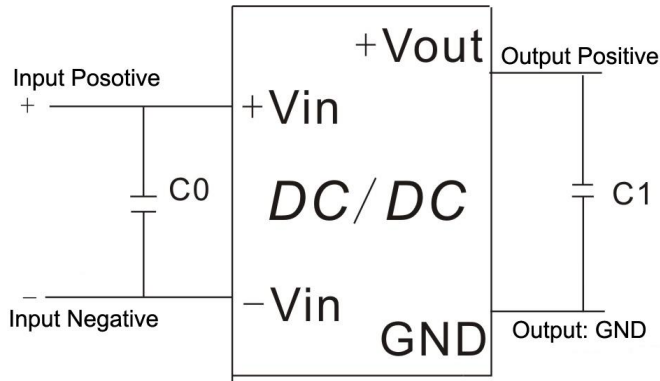

2. Input reflecting ripple current test circuit

Capacitor C choose low ESR ones, withstand voltage value should be bigger than max input voltage

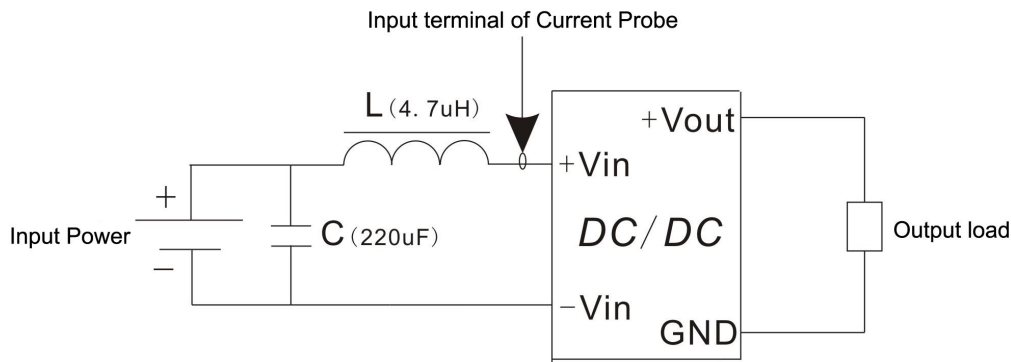

3. EMC external recommended circuit:

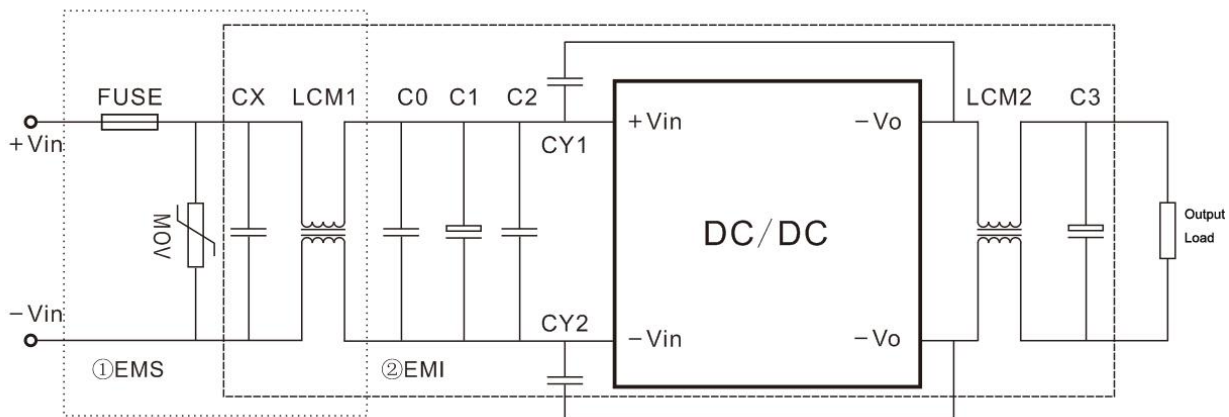

Recommended Spec:

Component	CFD20-18SXXB2C5 Input	CFD20-36SXXB2C5 Input
FUSE	Connect the corresponding fuse according to customer needs	
MOV	14D560K	14D101K
CX	0.47uF	0.47uF
LCM1	10mH	10mH
C0	1uF/100V	1uF/100V
C1	220uF/100V	220uF/100V
C2	1uF/100V	1uF/100V
LCM2	30uH	30uH
C3	47uF/50V	47uF/50V
CY1,CY2	2.2nF/2000V	

Note:

1. The product should be used under the specification range, otherwise it will cause permanent damage to it.
2. If the product worked beyond the load range or below the minimum load, we cannot ensure that the performance of product is in accordance with all the indexes in this manual;
3. Unless otherwise specified, data in this datasheet should be tested under conditions of Ta=25°C, humidity<75% when inputting nominal voltage and outputting rated load(pure resistance load);
4. All index testing methods in this datasheet are based on our Company's corporate standard.
5. The performance indexes of the product models listed in this manual are as above, but some indexes of non-standard model products will exceed the above-mentioned requirements, and please directly contact our technician for specific information;
6. We can provide customized product service;
7. The product specification may be changed at any time without prior notice.