

# CFD50-XXSXXB3C3(-T)(-TS) Series

## DC/DC Converter



### Product Typical Features

Wide input voltage range (4:1) Output Power 50W

Ultrathin Package: 13mm

Transfer Efficiency up to 90%

Stand-by Power Consumption as low as 3W

Output super-fast start up as low as 10ms

Continuous Short Circuit protection, Self-recovery

Input under voltage, output over voltage, short circuit, over current protection

Switching Frequency 300KHz

Isolation Voltage 3000VDC/1500VAC

Operating Temperature: -40°C~+85°C

Good EMI performance

International standard pin-out



CFD50-XXSXXB3C3 DC DC Converter with wide input voltage range(4:1), super-fast start up, isolated&regulated output, DIP/chassis mounting/DIN-Rail mounting, single output, isolation (3000VDC/1500VAC) function. It features the protection function of under-voltage, output over current, output short circuit, and output over voltage. It is widely used in the 72V, 96V, 110V of industrial control, electrical power, communication, engine, industrial robot, etc.

### Input Specification

Input Surge Voltage (1Sec)	110Vdc Input	160Vdc (Max)
Under-Voltage Turn-off	36VDC	
Start-up Time	10ms (Typ)	
Input Filter	Pi filter	
CTRL	Module turn-on	Suspended or connect to High level (3.5V-12VDC)
	Module turn-off	Connect to -Vin or connect to low level (0-1.2VDC)
	Input current when switched off	1mA(Typ)
Reflected Ripple Current	Input full range,connect to test tools	100mA

Note: \*The voltage of CTRL pin is relative to -Vin pin.

### Output Specification

Output Voltage Accuracy	Full voltage full load	Vo	≤±2.0% (Max)
Line Voltage Regulation	Nominal load, full voltage range	Vo	≤±1.0%
Load Regulation	10% ~ 100% nominal load	Vo	≤±1.0%

# CFD50-XXSXXB3C3(-T)(-TS) Series

## DC/DC Converter



Ripple & Noise	Nominal load, nominal voltage	$\leq 200\text{mVp-p}$ (20MHz bandwidth)	
Output Over-voltage Protection	110%~190%Vo		
Output Voltage Adjustment	Trim-pin function	$\pm 10\%$ (Typ)	
Output Short circuit Protection	Hiccup, continuous, self-recovery		
Output Over-current protection	110%~200%Io		
Dynamic Response	25% nominal load step change	$\Delta V_o/\Delta t$	$\leq \pm 5.0\%/500\mu\text{s}; (3V3, 5.0V \text{ Series}) \leq \pm 8.0\%/500\mu\text{s}$

### General Specification

Switching Frequency	Typical	300KHz
Isolation Capacitor	Typical	2000pF
Operating Temperature	Refer to Temperature Derating Curve	-40°C ~ +85°C
Storage Temperature	-	-55°C ~ +125°C
Max Case Temperature	Within Operating Curve	+105°C
Relative Humidity	No condensing	5%~95%
Case Material	-	Aluminum Metal Case
Isolation Voltage	Input to Output	3000Vdc $\leq$ 0.5mA / 1min    1500VAc $\leq$ 5mA / 1min
Meantime Between Failure	MIL-HDBK-217F@25°C	2X10 <sup>5</sup> Hrs
Product Weight	Average	30g

### Typical Product List

Part No	Input Voltage Range (VDC)		Output Voltage/Current (Vo/Io)		Input Current (mA) (Nominal Voltage)		Max. Capacitive Load u F	Ripple & Noise 20MHz (MAX) mVp-p (mV)	Efficiency (%)	
	Nominal	Range	Voltage (V)	Current (A)	Full load (mA)	No Load (mA)			Min	Typ
CFD50-110S3V3B3C3	110	40-160	3.3	10	345	25	10000	100	83	85
CFD50-110S05B3C3			5	10	525	25	8000	100	84	86
CFD50-110S12B3C3			12	4.167	525	2	3300	200	86	88
*CFD50-110S15B3C3			15	3.333	525	2	1200	200	86	88
CFD50-110S24B3C3			24	2.083	525	2	680	200	87	89
*CFD50-110S48B3C3			48	1.042	525	2	470	200	87	89

# CFD50-XXSXXB3C3(-T)(-TS) Series

## DC/DC Converter



1. “\*” are models being developing; Suffix “C” is with CTRL function;
2. “-H” suffix is with heat sink, “-T(H)” suffix for chassis mounting(with heat sink);“-TS(H)” suffix for DIN-Rail mounting(with heat sink), DIN-Rail width is: 35mm;
3. Max capacitive load is, when the power supply is fully loaded, the max capacity could be connected to output, if exceed, the power supply cannot start-up;
4. To reduce no load power consumption and improve efficiency of light-load, IC will be flitter frequency under no-load and light-load operating,
5. Output cannot be no load, at least with 5% load or above 470uF high frequency low resistance electrolytic capacitor, otherwise the output ripple will rise;

### Temperature Derating Curve

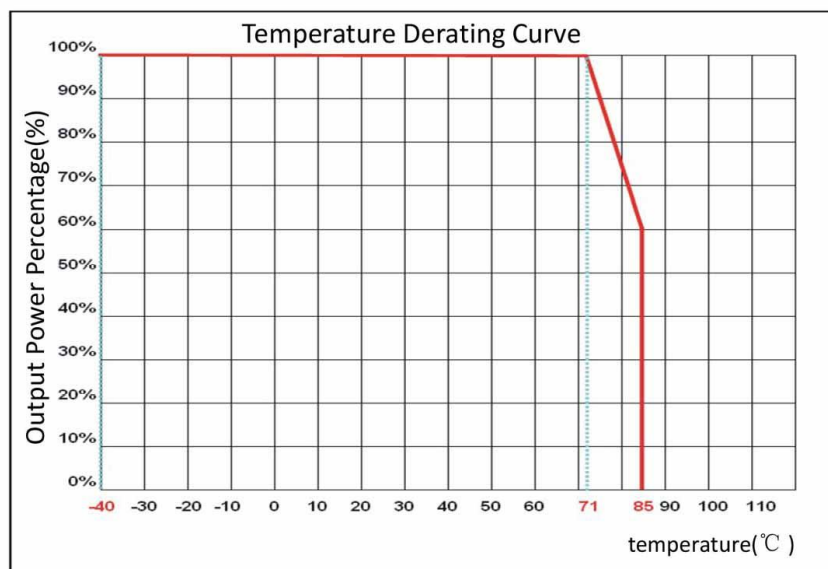

### EMC Characteristics

EMI	CE	CISPR22/EN55032 CLASSB (external circuit is needed)	
	RE	CISPR22/EN55032 CLASSB (external circuit is needed)	
EMS	ESD	IEC/EN61000-4-2 Contact ±4KV	perf.Criteria B
	RS	IEC/EN61000-4-3 10V/m	perf.Criteria A
	EFT	IEC/EN61000-4-4 ±2KV (external circuit is needed)	perf.Criteria B
	CS	IEC/EN61000-4-6 3Vr.m.s	perf.Criteria A
	Voltage dips, short interruptions and voltage variations immunity	IEC/EN61000-4-29 0%-70%	perf.Criteria B

/

**EMC External Recommended Circuit**

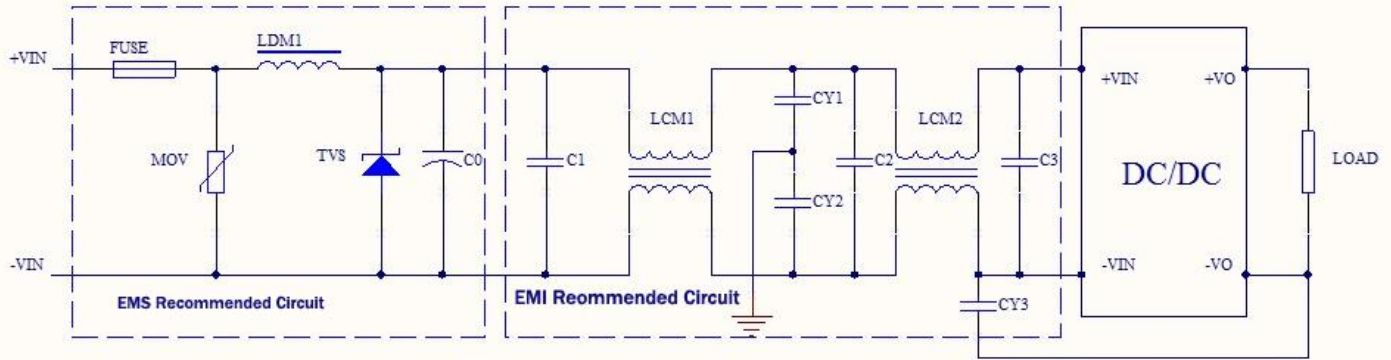

**Recommended Parameter: :**

Component	110V Input
FUSE	According to customer's request
MOV	14D201K
LDM1	56uH
TVS	SMCJ170A
C0	560uF/200V
C1,C2,C3	4.7uF/200V
LCM1	15mH
LCM2	56uH
CY1,CY2,CY3	1nF/3KV

/

**B3 Package(without Heat Sink) Dimension and Pin Function**

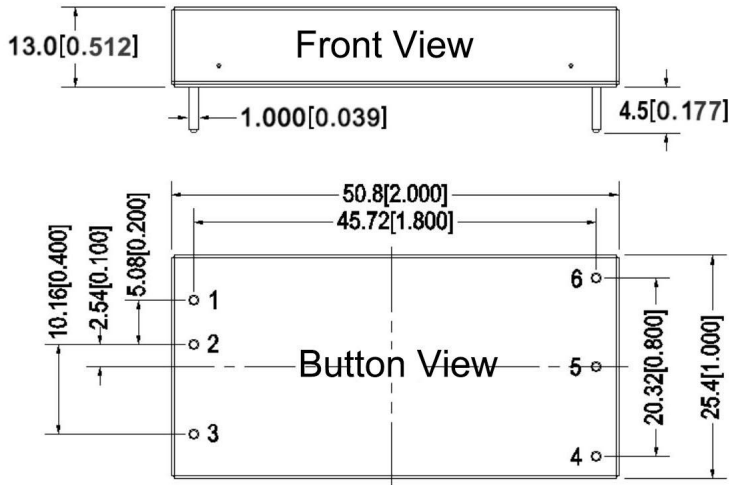

Note:  
 Unit:mm[inch]  
 Pin diameter tolerance:  $\pm 0.10[\pm 0.004]$   
 General tolerances: $\pm 0.50[\pm 0.020]$

	1	2	3	4	5	6
Single (S)	+Vin	-Vin	CTRL	Trim	-Vo	+Vo

Note: If the definition of pin is not in accordance with the model selection manual, please refer to the label on actual item.

**B3-H Package (with Heat Sink) Dimension and Pin Function**

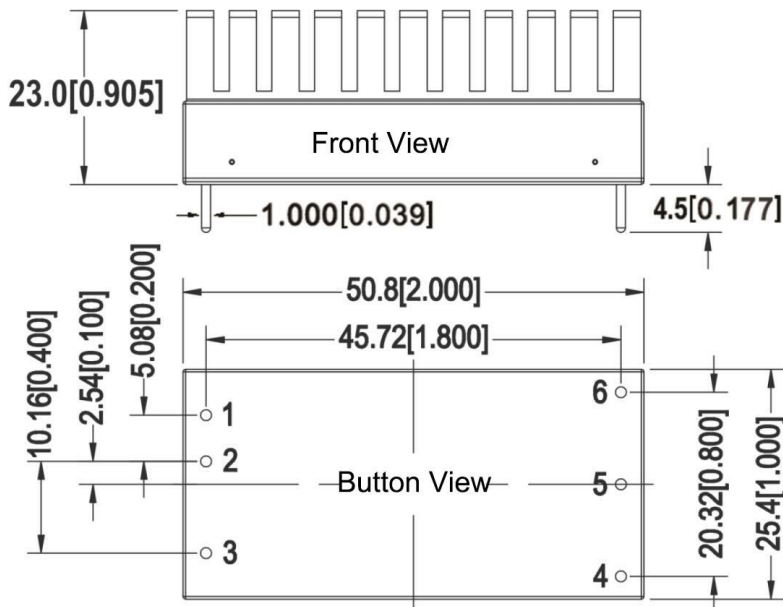

Note:  
 Unit:mm[inch]  
 Pin diameter tolerance:  $\pm 0.10[\pm 0.004]$   
 General tolerances: $\pm 0.50[\pm 0.020]$

B3-T Package(without Heat Sink) Dimension

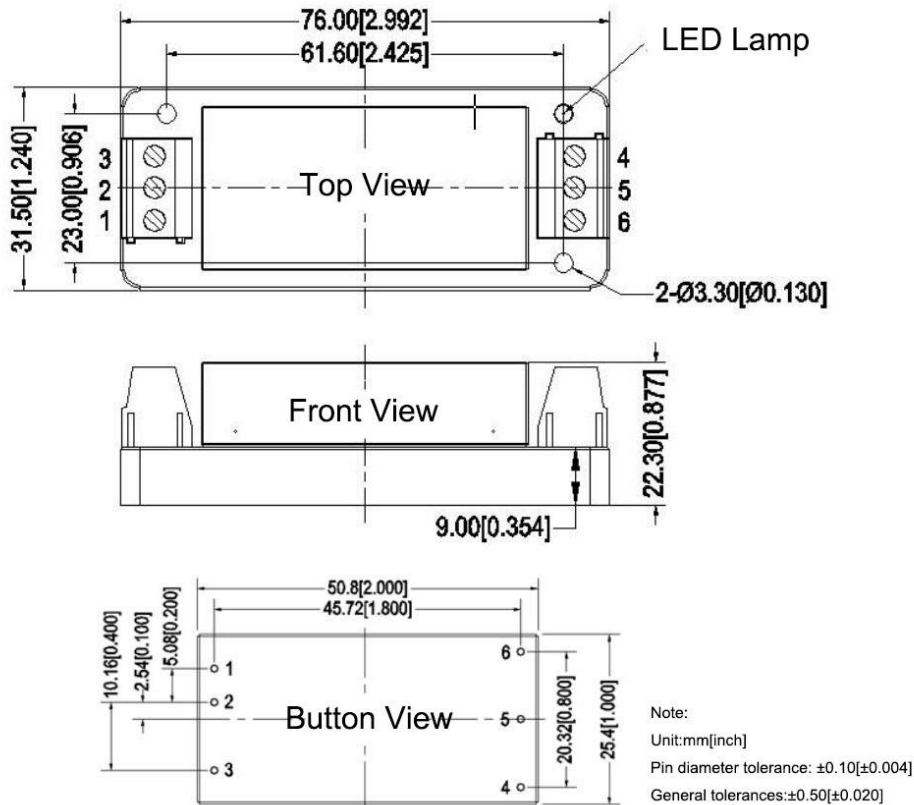

B3-T Package(with Heat Sink) Dimension

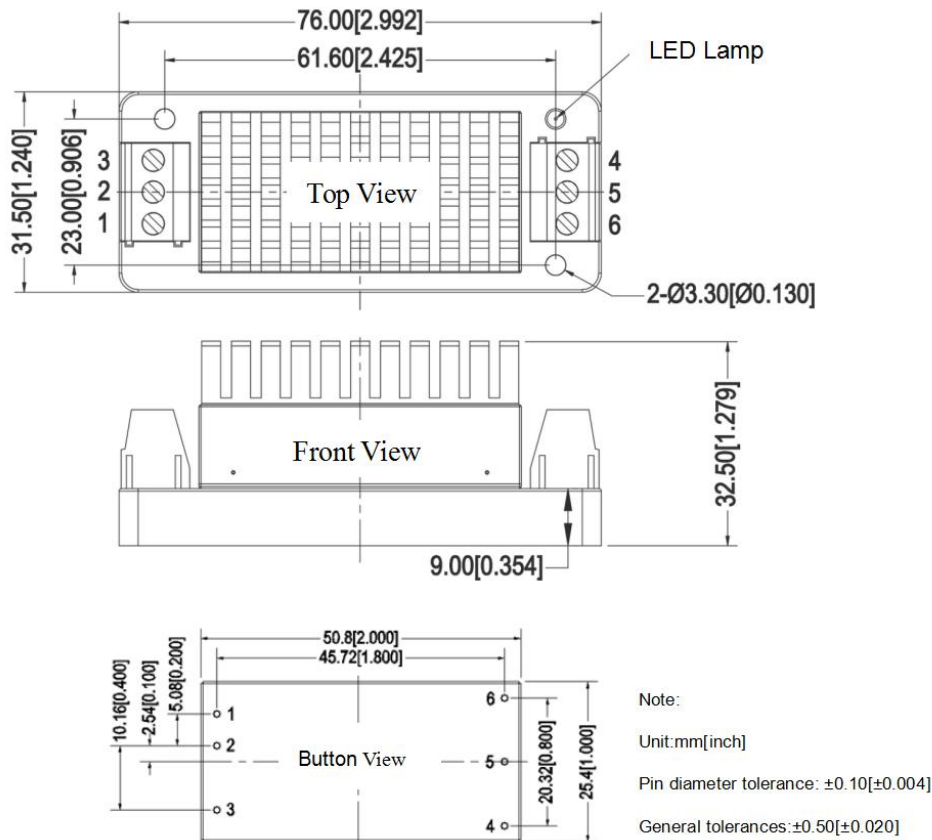

B3-TS Package(without Heat Sink) Dimension

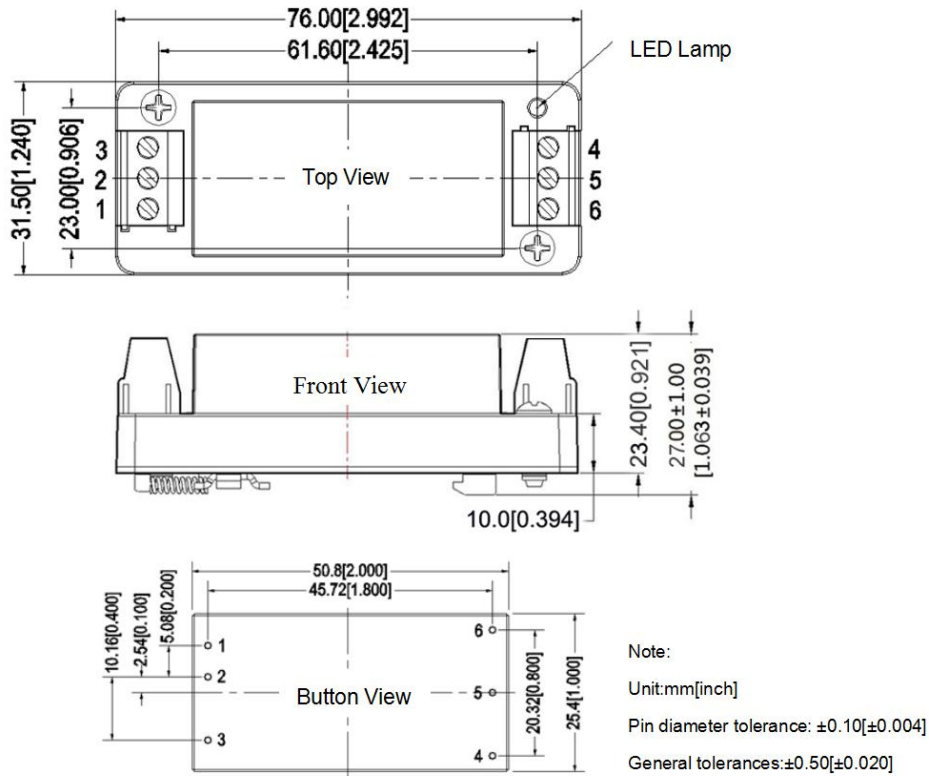

B3-TS Package(with Heat Sink) Dimension

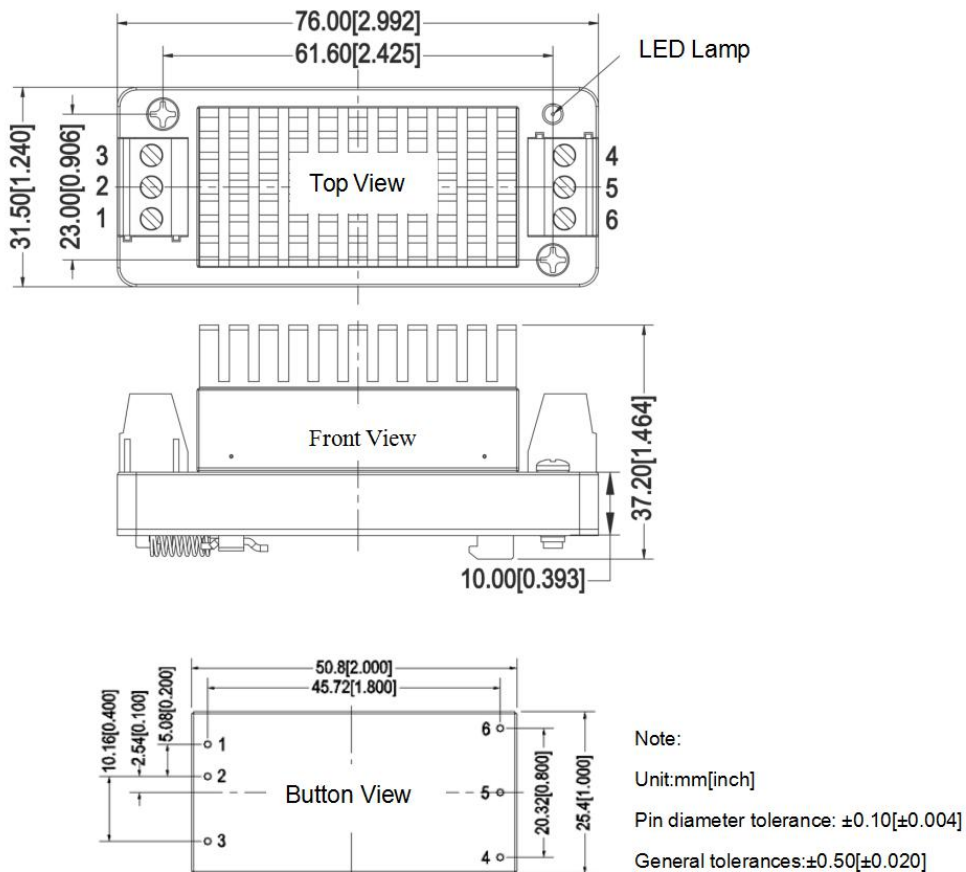

### Package Description

Packing Code	L x W x H	
B3 (without Heat Sink)	50.80X25.40X13mm	2.000X1.000X0.511inch
B3-H (with Heat Sink)	50.80X25.40X23mm	2.000X1.000X0.905inch
B3-T (without Heat Sink)	76X31.5X22.3mm	2.99X1.24X0.877inch
B3-TH (with Heat Sink)	76X31.5X32.5mm	2.99X1.24X1.279inch
B3-TS (without Heat Sink)	76X31.5X27mm	2.99X1.24X1.063inch
B3-TSH (with Heat Sink)	76X31.5X37.2mm	2.99X1.24X1.464inch

### The usage of Trim and Calculating Trim resistor values

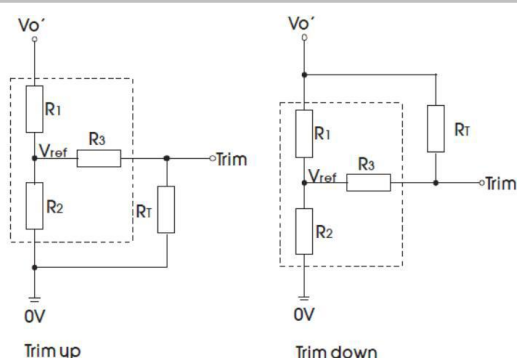

Calculating Trim resistor values:

$$\text{up: } R_T = \frac{\alpha R_2}{R_2 - \alpha} - R_3 \quad \alpha = \frac{V_{ref}}{V_o' - V_{ref}} \cdot R_1$$

$$\text{down: } R_T = \frac{\alpha R_1}{R_1 - \alpha} - R_3 \quad \alpha = \frac{V_o' - V_{ref}}{V_{ref}} \cdot R_2$$

RT= Trim Resistor value;  
 a= self-defined parameter, no actual meaning;  
 Vo' is the actula voltage to increas or desearse;

The usage circuit of the Trim circuit(dashed line shows internal resistor network)

Vout(VDC)	R1(KΩ)	R2(KΩ)	R3(KΩ)	Vref(V)
3.3	24	14.53	68	1.25
5	24	24	68	2.5
9	12.1	4.62	30	2.5
12	18	4.7	30	2.5
15	24	4.78	30	2.5
24	25.5	2.955	18	2.5

/



### Design and Application Reference

#### Recommended circuit

1. DC/DC test circuit:

Normal recommended capacitors:

C0: 47-100uF; C1: 10-22uF.

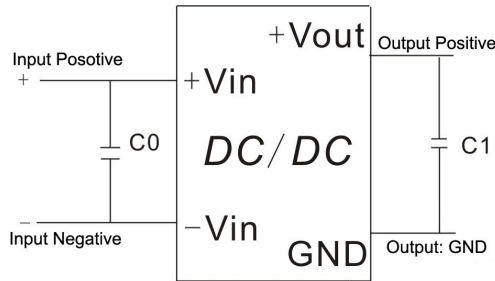

2. Input reflecting ripple current test circuit:

Capacitor C choose low ESR ones, withstand voltage value should be bigger than max input voltage;

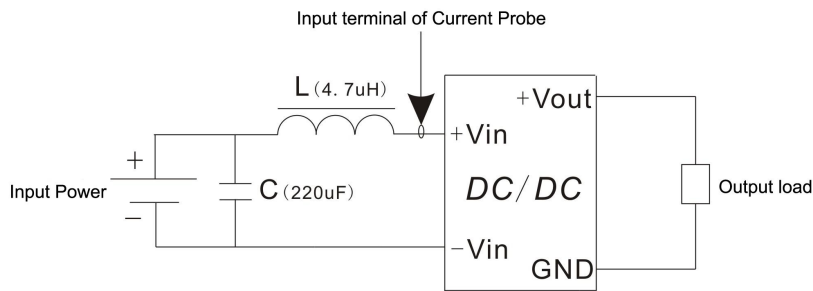

#### Ripple & Noise Test:

1. 12# twisted pair to connect, Oscilloscope bandwidth set as 20MHz, 100M bandwidth probe, terminated with 0.1uF polypropylene capacitor and 47uF high frequency low resistance electrolytic capacitor in parallel, oscilloscope set as Sample pattern.

2. Output Ripple & Noise Test Method:

Input terminal connect to power supply, output terminal connect to electronic load through jig plate, Use 30cm±2 cm sampling line, Power line selected from corresponding diameter wire with insulation according to the flow of output current.

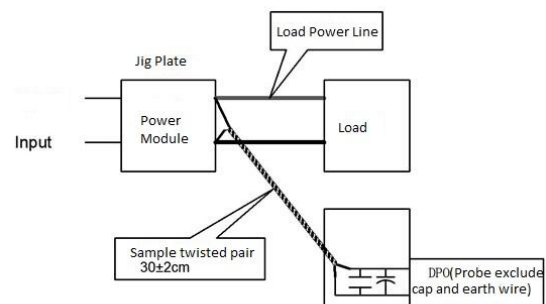

#### Application Reference:

1. The recommended minimum load is 10% or high frequency low resistance electrolytic capacitor above 470uF, or output ripple will rise;
2. Recommend the unbalance loads of dual output to be  $\leq \pm 5\%$ ;
3. The maximum capacitive load is tested under pure resistance and full load condition;
4. Our company could provide whole power supply solution, or customized made items;
5. Due to space limitation, please contact our team for more information;
6. If no special specified, all parameters tested under nominal input voltage, pure resistance rated load and  $T_a = 25^\circ\text{C}$  conditions.