

CFD6-XXSXXA3 (-T)(-TS) Series DC/DC Converter



Product Typical Features

- ◆ Wide input voltage range(4:1), Output Power 6W
- ◆ Transfer Efficiency up to 84%
- ◆ Short Circuit protection, Self-recovery
- ◆ Protection: over voltage, over current
- ◆ Switching Frequency 250KHz
- ◆ Isolation Voltage: 1500VDC
- ◆ Operating Temperature: -40°C~+85°C
- ◆ Good electromagnetic compatibility EMI
- ◆ International standard pin-out



Test Condition: Unless otherwise specified, all parameters are tested under nominal input voltage, pure resistive rated load and 25°C room temperature.

Application Field

CFD6-XXSXXA3 is a newly designed DIP 1X1 packed, 6W output power, ultra wide input range 4:1, low stand-by power consumption, isolated regulated output DC-DC converter, could be widely used for industrial control, instrument, communication, power electricity, internet of things field.

Typical Product List

Part No	Input Voltage Range (VDC)		Output Voltage/Current (Vo/Io)		Input Current (mA) Nominal Voltage		Max. Capacitive Load uF	Ripple & Noise		Efficiency (%)@output full load, input nominal voltage	
	Nominal	Range	Voltage (VDC)	Current (mA) MAX./Min.	Full load typ.	No Load typ.		mVp-p		Min.	Typ.
								Typ.	Max.		
CFD6-18S3V3A3	24	9-36	3.3	1200/0	220	25	1000	30	80	73	75
CFD6-18S05A3			5	1200/0	330	25	1000	30	80	74	76
CFD6-18S6V2A3			6.2	1000/0	431	25	1000	30	80	80	82
CFD6-18S09A3			9	667/0	316	25	470	30	80	77	79
CFD6-18S12A3			12	500/0	313	25	330	30	80	78	80
CFD6-18S15A3			15	400/0	313	25	220	30	80	78	80
CFD6-18S24A3			24	250/0	305	25	100	30	80	80	82
CFD6-36S3V3A3	48	18-75	3.3	1200/0	109	10	1000	30	80	74	76
CFD6-36S05A3			5	1200/0	154	10	1000	30	80	79	81
CFD6-36S09A3			9	667/0	152	10	470	30	80	80	82
CFD6-36S12A3			12	500/0	149	10	330	30	80	82	84
CFD6-36S15A3			15	400/0	149	13	220	30	80	82	84

CFD6-XXSXXA3 (-T)(-TS) Series DC/DC Converter



CFD6-36S24A3		24	250/0	149	13	100	30	80	82	84
--------------	--	----	-------	-----	----	-----	----	----	----	----

1. "-T" suffix for chassis mounting, "-TS" suffix for DIN-Rail mounting, DIN-Rail width is: 35mm;
2. The maximum capacitive load refers to the capacity of the capacitor that is allowed to be connected when the power supply is fully loaded. If this capacity is exceeded, the power supply may not be able to start.

Input Specification

Stand-by Consumption	0.5W(TYP)
Input Filter	π filter

Output Specification

Main Circuit Output Voltage Accuracy	Full voltage full load	Vo	$\pm 2.0\%$ (max)
Voltage Regulation	Nominal load, full voltage	Vo	$\leq \pm 0.5\%$
Load Regulation	10% ~ 100% nominal load	Vo	$\leq \pm 1.0\%$
Ripple & Noise	Nominal load, nominal voltage Twisted Pair Method, 20M Hz bandwidth;	$\leq 15\%$ load	5%Vo mVp-p Typ
		$\geq 15\%$ load	50mVp-p Typ, 80mVp-p
Output overvoltage protection	120%~200%Vo		
Output Over-load Protection	120%~220%		
Output Short circuit Protection	Self-recovery, (The longest time does not exceed 5S)		
Dynamic Response	25% nominal load step change	$\Delta Vo/\Delta t$	$\leq 6\%/500\mu s$
Turn-on delay time	Typical	250ms	
Output Turn-on Overshoot Voltage			$\leq 10\%Vo$

General Specification

Switching Frequency	Typical	250KHz
Operating Temperature	Refer to Temperature Derating Curve	-40°C ~ +85°C
Storage Temperature		-55°C ~ +125°C
Max Case Temperature	Within Operating Curve	+105°C
Relative Humidity	No condensing	5%~95%
Case Material		Aluminum Metal Case
Cooling Method		Free air convection
Isolation Voltage	Input to Output	1500Vdc \leq 0.5mA / 1min
Meantime Between Failure	MIL-HDBK-217F@25°C	2X10 ⁵ Hrs

**CFD6-XXSXXA3 (-T)(-TS) Series
DC/DC Converter**



Product Weight	Average	14g
----------------	---------	-----

EMC Characteristics

Total Items		Sub Items	Test Standard	Class
EMC	EMI	CE	CISPR22/EN55032	CLASS B (see recommended circuit photo ②)
		RE	CISPR22/EN55032	CLASS B (see recommended circuit photo ②)
	EMS	RS	IEC/EN61000-4-3	10V/m Perf.Criteria B (see recommended circuit photo 2)
		CS	IEC/EN61000-4-6	3Vr.m.s Perf.Criteria B (see recommended circuit photo 2)
		ESD	IEC/EN61000-4-2	Contact ±4KV Perf.Criteria B
		Surge	IEC/EN61000-4-5	±2KV Perf.Criteria B (see recommended circuit photo 1)
		EFT	IEC/EN61000-4-4	±2KV Perf.Criteria B (see recommended circuit photo 1)
		Voltage dips, short interruptions and voltage variations immunity	IEC/EN61000-4-11	0%~70% Perf.Criteria B

A3 Packing Dimension

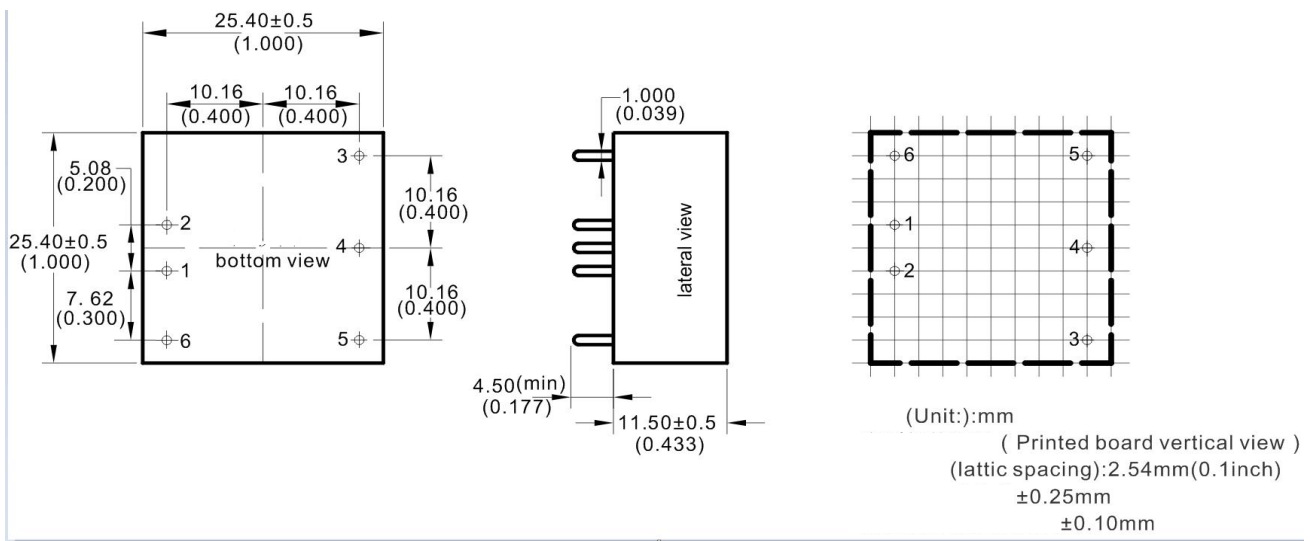

A3-T Package Dimension

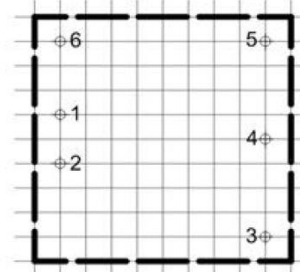
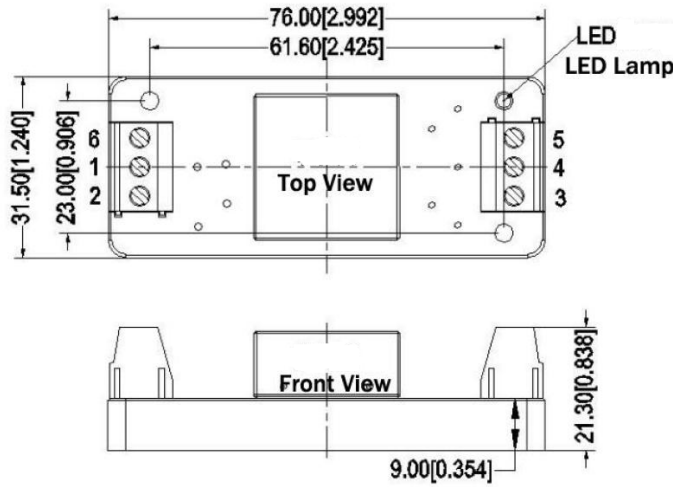

(Unit):mm
 (Printed board vertical view)
 (latic spacing):2.54mm(0.1inch)
 ±0.25mm
 ±0.10mm

A3-TS Packing Dimension

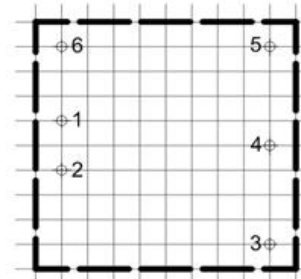
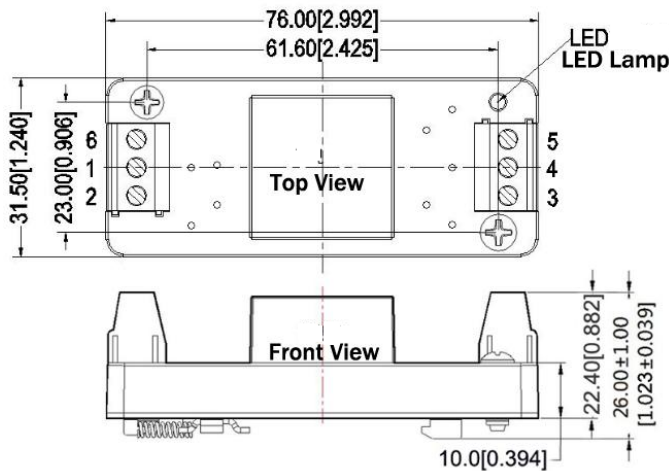

(Unit):mm
 (Printed board vertical view)
 (latic spacing):2.54mm(0.1inch)
 ±0.25mm
 ±0.10mm

Packing Code	L x W x H	
A3	25.4X 25.4X11.5 mm	1X1 X0.433inch
A3-T	76X31.5X21.3mm	2.99X1.24X0.838inch
A3-TS	76X31.5X26mm	2.99X1.24X1.023inch

Pin out Specifications

	1	2	3	4	5	6
Single (S)	-Vin	+Vin	+Vout	NC	GND	NC

Note: If the definition of pin is not in accordance with the model selection manual, please refer to the label on actual item.

Ripple & Noise Test: (Twisted Pair Method 20MHZ bandwidth)

Test Method:

a. 12# twisted pair to connect, Oscilloscope bandwidth set as 20MHz, 100M bandwidth probe, terminated with 0.1uF polypropylene capacitor and 10uF high frequency low resistance electrolytic capacitor in parallel, oscilloscope set as Sample pattern.

b. Input terminal connect to power supply, output terminal connect to electronic load through jig plate, Use 30cm ± 2 cm sampling line, Power line selected from corresponding diameter wire with insulation according to the flow of output current.

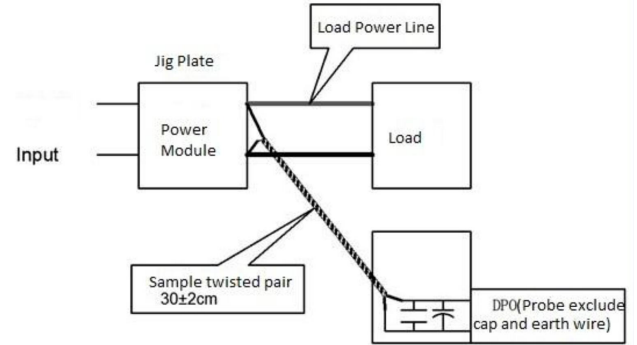

Application Reference:

1. The recommended minimum load is 10% or above 470uF high frequency low resistance electrolytic capacitor, or output ripple will rise;
2. Recommend the unbalance loads of dual output to be $\leq \pm 5\%$;
3. The maximum capacitive load is tested under pure resistance and full load condition;
4. Our company could provide whole power supply solution, or customized made items; Due to space limitation, please contact our team for more information.

Product Characteristic Curve

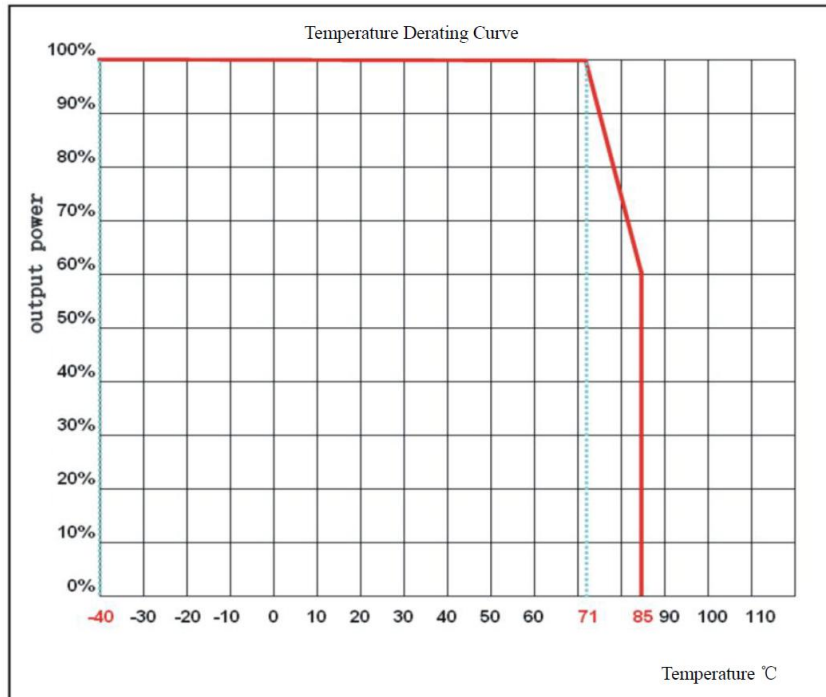

Design Application

Recommended circuit

1. DC/DC test circuit:

Normal recommended capacitors: C0: 47-100uF; C1: 470uF.

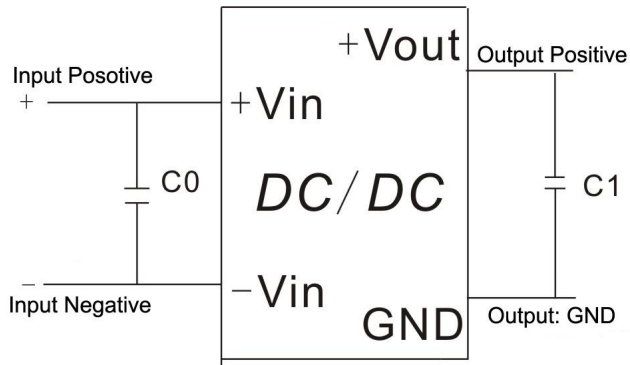

2. Input reflecting ripple current test circuit:

Capacitor C choose low ESR ones, withstand voltage value should be bigger than max input voltage;

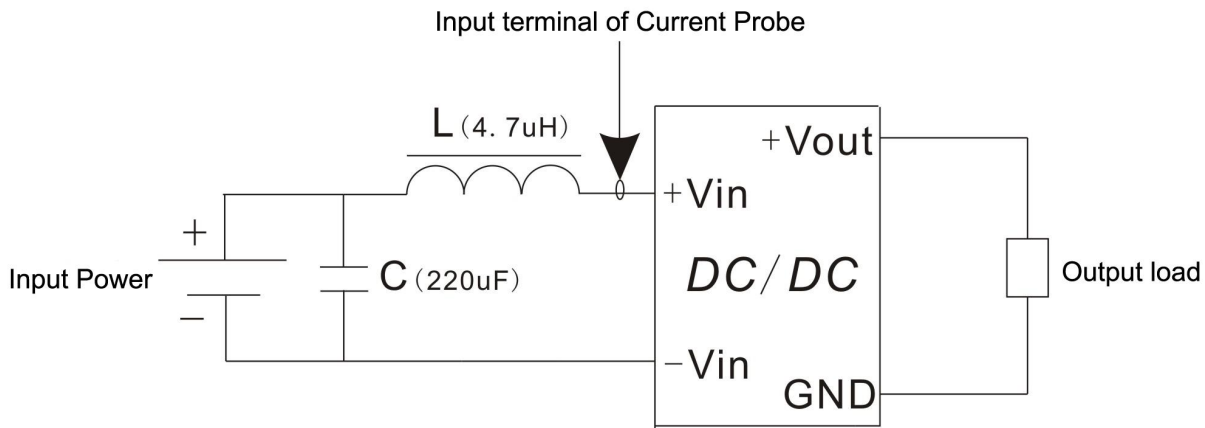

3. EMC external recommended circuit:

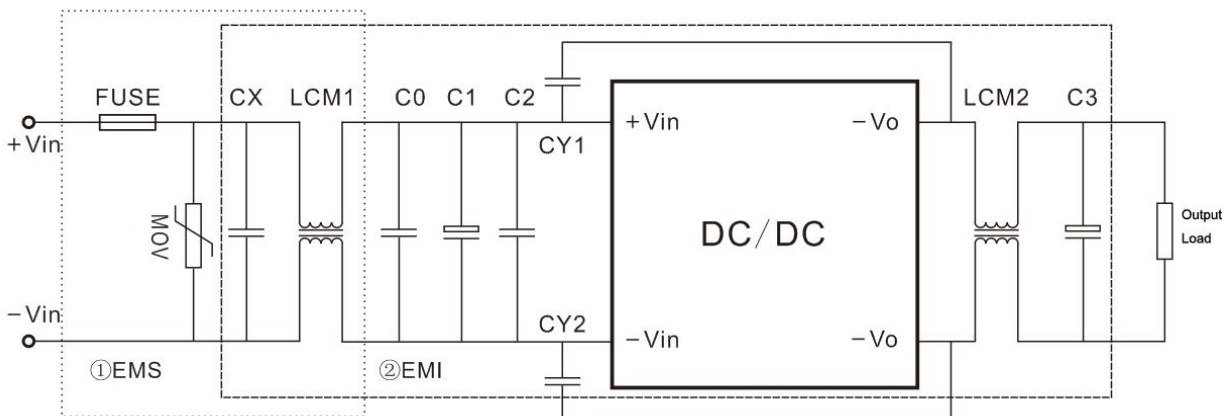

Recommended Spec:

Component	CFD6-18SXXA3 Input	CFD6-36SXXA3 Input
FUSE	According to customer's request	
MOV	14D560K	14D101K
CX	4.7uF/100V	4.7uF/100V
LCM1	10mH	10mH
C0	4.7uF/50V	1uF/100V
C1	220uF/100V	220uF/100V
C2	4.7uF/50V	1uF/100V
LCM2	30uH	30uH
C3	47uF/50V	47uF/50V
CY1,CY2	1nF/2000V	

Note:

1. The product should be used under the specification range, otherwise it will cause permanent damage to it.
2. If the product worked beyond the load range or below the minimum load, we cannot ensure that the performance of product is in accordance with all the indexes in this manual;
3. Unless otherwise specified, data in this datasheet should be tested under conditions of $T_a=25^{\circ}\text{C}$, humidity<75% when inputting nominal voltage and outputting rated load(pure resistance load);
4. All index testing methods in this datasheet are based on our Company' s corporate standards
- 5.The performance indexes of the product models listed in this manual are as above, but some indexes of non-standard model products will exceed the above-mentioned requirements, and please directly contact our technician for specific information;
6. We can provide customized product service;
7. The product specification may be changed at any time without prior notice.