

### Typical Features

- ◆ Wide input voltage range (4:1), Output Power 6W
- ◆ Transfer Efficiency up to 84%
- ◆ Continuous Short Circuit protection, Self-recovery
- ◆ Protections: Input under voltage, output short circuit, over current
- ◆ Switching Frequency 500KHz
- ◆ Isolation Voltage 3000 VDC
- ◆ Operating Temperature: -40°C~+85°C
- ◆ Good EMI performance



### Application Field

**CFK6-XXDXXE2C3** The newly developed DC-DC module power supply for our company, SIP package, 6W output power, ultra-wide voltage input range, ultra-low standby power consumption, isolated and regulated single output, can be widely used in industrial control, instrumentation, communication, Electricity, Internet of Things, BMS and other fields.

### Typical Product List

Part no.	Input Voltage Range (VDC)		Output Voltage/Current (Vo/Io)		Input Current (mA) (Nominal Voltage)		Max. Capacitive Load uF	Ripple & Noise		Efficiency (%) output full load, I/P nominal voltage	
	Nominal	Range	Voltage (VDC)	Current (mA) Max./Min	Full load typ.	No Load typ.		mVp-p		Min.	Typ.
								Typ.	Max		
CFK6-18D05E2C3	24	9-36	±5	±600/0	305	5	1000	100	150	80	82
CFK6-18D09E2C3			±9	±333/0	294	6	470	100	150	83	85
CFK6-18D12E2C3			±12	±250/0	296	8	220	100	150	81	83
CFK6-18D15E2C3			±15	±200/0	296	6	220	100	150	81	83
CFK6-18D18E2C3			±18	±167/0	300	7	180	100	150	81	83
CFK6-18D24E2C3			±24	±125/0	305	9	100	100	150	80	82

1. The maximum capacitive load refers to the capacity of the capacitor that is allowed to be connected when the power supply is fully loaded. If the capacity is exceeded, the power supply may not be able to start;

2. With "C", it has control pin function;

### Input Specification

Input Filter	capacitor filter	
Input Under-Voltage Protection	6-7 VDC	
CTRL*	Module turn-on	CTRL suspended or TTL high level (3.5-12VDC)

	Module turn-off	CTRL connect to GND or low level (0-1.2VDC)
	Input current when switched off	5mA (TYP)

Note: \*The voltage of CTRL pin is relative to GND pin.

### Output Specification

Output Voltage Accuracy	Full voltage full load	Vo1	±2.0%max
		Vo2	±3.0%max
Line Regulation	Nominal load, full voltage range	Vo1	±1.0%max
		Vo2	±1.5%max
Load regulation	10% ~ 100% nominal load	Vo1	±1.5%max
		Vo2	±2.0%max
Ripple & Noise	Nominal load, nominal voltage, Twisted Pair Test Method, 20M Hz Bandwidth	Vp-p ≤ 150mV	
Output Over-load Protection	110%~230%		
Output Short circuit Protection	Continuous, self-recovery		
Dynamic Response	25% nominal load step $\Delta V_o/\Delta t$	5V Output	±5% typ., ±8% max /500us
		Other voltage output	±3% typ., ±5% max /500us
Output Voltage Adjustment	No adjustment		
Turn-on delay time	Typical	100ms	
Output Turn-on Overshoot Voltage		≤10%Vo	

### General Specification

Switching Frequency	Typical	500KHz
Operating Temperature	Refer to Temperature Derating Curve	-40°C ~ +85°C
Storage Temperature	-	-55°C ~ +125°C
Max Case Temperature	Within Operating Curve	+105°C
Relative Humidity	No condensing	5%~95%
Case Material		Black flame-retardant and heat-resistant plastic
Cooling Method		Natural air cooling
Isolation Voltage	Input to Output	3000Vdc ≤0.5mA / 1min
MTBF	MIL-HDBK-217F@25°C	2X10 <sup>5</sup> Hrs
Product Weight	Average	5.0 g

**EMC Characteristics**

Total Items		Sub Items	Test Standard	Class		
EMC	EMI	CE	CISPR22/EN55032	CLASS B (see recommended circuit photo)		
		RE	CISPR22/EN55032	CLASS B (see recommended circuit photo)		
	EMS	RS	IEC/EN61000-4-3	10V/m	Perf.Criteria A	
		CS	IEC/EN61000-4-6	3Vr.m.s	Perf.Criteria A	
		ESD	IEC/EN61000-4-2	Contact ±4KV	Perf.Criteria B	
		Surge	IEC/EN61000-4-5	±2KV	Perf.Criteria B (see recommended circuit photo)	
		EFT	IEC/EN61000-4-4	±2KV	Perf.Criteria B (see recommended circuit photo)	

**Packing Dimension**

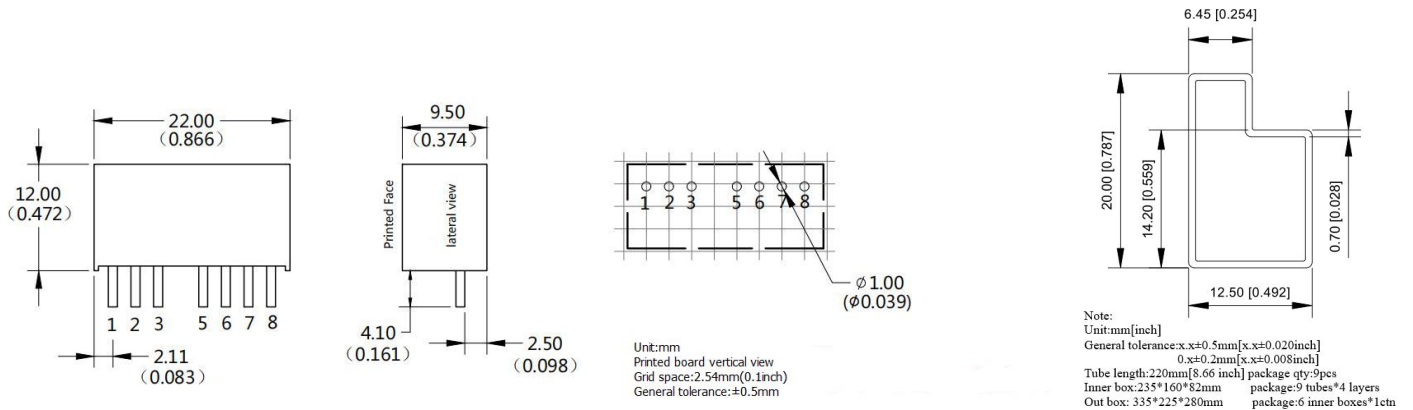

Packing Code	L x W x H
E	22X 9.5X12 mm

**Pin out Specifications**

Dual output (S)	1	2	3	5	6	7	8
	-Vin	+Vin	CTRL	NC	+Vout	0V	-Vout

**Ripple & Noise Test: (Twisted Pair Test Method 20MHz bandwidth)**

1. 12# twisted pair to connect, Oscilloscope bandwidth set as 20MHz, 100M bandwidth probe, terminated with 0.1uF polypropylene capacitor and 10uF high frequency low resistance electrolytic capacitor in parallel, oscilloscope set as Sample pattern.

**2. Output Ripple & Noise Test Method:**

Input terminal connect to power supply, output terminal connect to electronic load through jig plate, Use 30cm±2 cm sampling line, Power line selected from corresponding diameter wire with insulation according to the flow of output current.

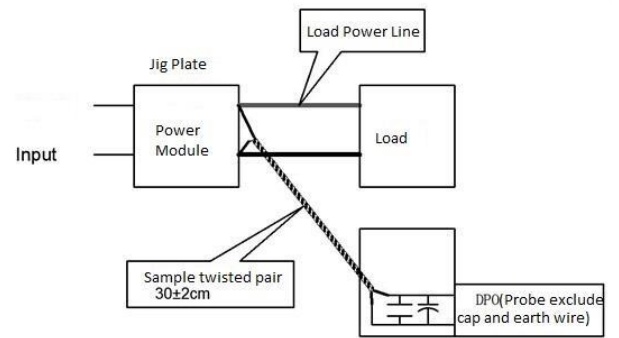

**Application reference:**

1. It is recommended to output a minimum of 10% load or connect an electrolytic capacitor with a high-frequency resistance above 470uF, otherwise it will increase the output voltage ripple;
2. It is recommended that the load imbalance of dual output products is less than ±5%;
3. The maximum capacitive load is the result of the pure resistance full load condition test;
4. Our company can provide overall power supply solutions, or product customization;

**Product characteristic curve**

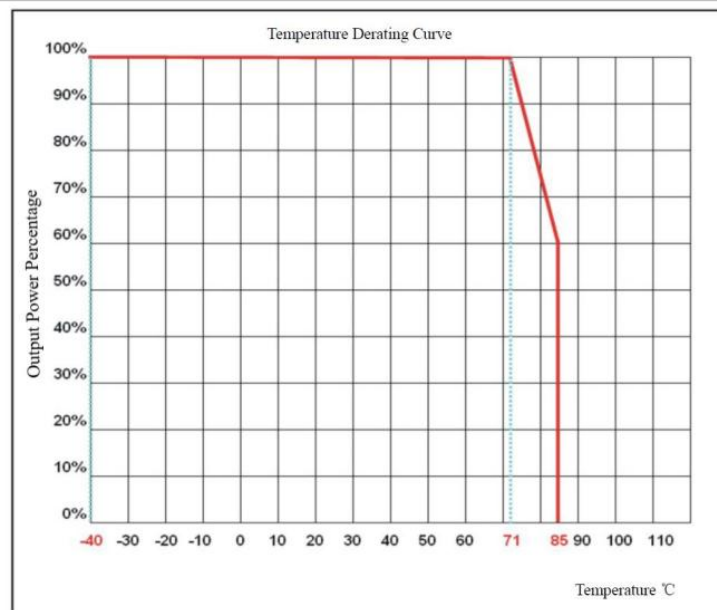

**Design reference application**

**Recommended circuit**

**1.DC/DC test circuit:**

Normal recommended capacitors:C0:47-100uF; C1,C2:22uF.

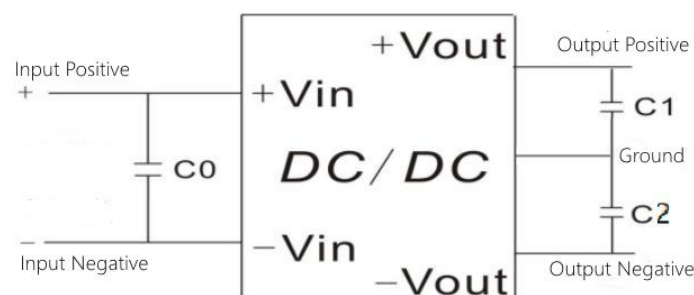

## 2. Input reflecting ripple current test circuit:

Capacitor C choose low ESR ones, withstand voltage value should be bigger than max input voltage;

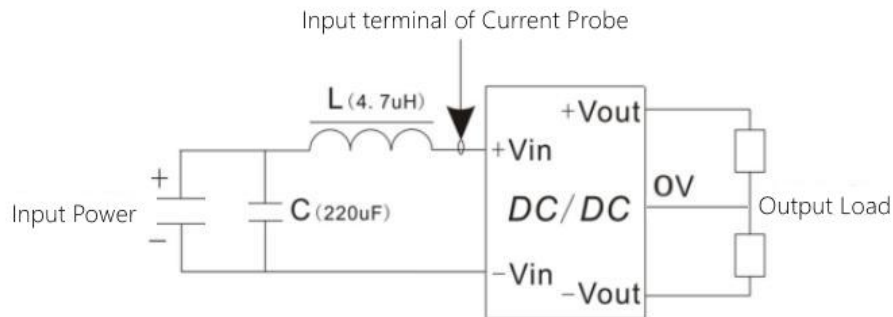

## 3. EMC external recommended circuit:

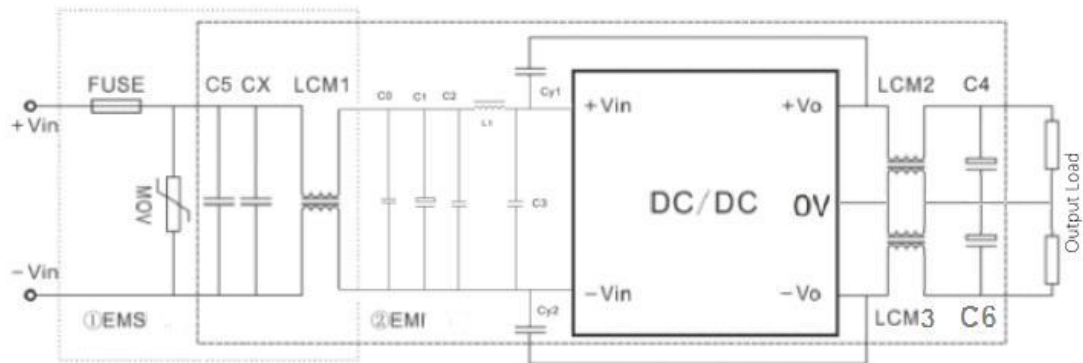

## Recommend specs:

Component	FK6-18DXXE2 Input
FUSE	According to customer's request
MOV	14D560K
CX	0.47uF
LCM1	20mH
C5	1000uF/50V
C0	1uF/100V
C1	220uF/50V
C2,C3	1uF/100V
L1	4.7uH
LCM2, LCM3	30uH
C4, C6	22uF/50V
CY1,CY2	2.2nF/2000V

Note:

1. The product should be used under the specification range, otherwise it will cause permanent damage to it.
2. If the product worked beyond the load range or below the minimum load, we cannot ensure that the performance of product is in accordance with all the indexes in this manual;
3. Unless otherwise specified, data in this datasheet should be tested under conditions of  $T_a=25^{\circ}\text{C}$ , humidity<75% when inputting nominal voltage and outputting rated load(pure resistance load);
4. All index testing methods in this datasheet are based on our Company's corporate standards
5. The performance indexes of the product models listed in this manual are as above, but some indexes of non-standard model products will exceed the above-mentioned requirements, and please directly contact our technician for specific information;
6. We can provide customized product service;
7. The product specification may be changed at any time without prior notice. Please pay attention to the latest manual published on our official website.



[www.contra-solution.de](http://www.contra-solution.de)

**CONTRA-Solution GmbH**

**Vogelanger 15 - 82319 Starnberg / Germany**