

Typical Features

- ◆ Wide input voltage range, non-Isolated & regulated single output
- ◆ High Efficiency up to 96%
- ◆ No load input current as low as 0.2mA
- ◆ Short circuit protection
- ◆ Support the negative output
- ◆ Operating Temperature: -40°C ~ +85°C
- ◆ Plastic Case, meet UL94 V-0 standard

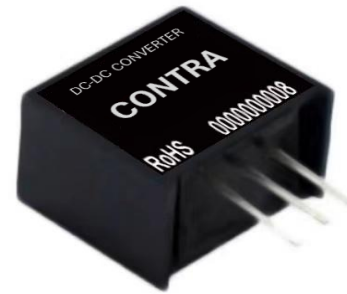

Test Condition: Unless otherwise specified, data in the datasheet should be tested under the conditions of inputting nominal voltage, pure resistance rated load and $T_a=25^\circ\text{C}$

Typical Product List

Part No.	Input Voltage Range (VDC)	Output		Quiescent Current (mA)	Capacitive Load(μF)	Ripple & Noise mVp-p	Efficiency (%) (Typ.)	
		Voltage (VDC)	Current (mA)				Typ.	Min (Max)
CK783V3M-1000R3	24 (6 – 34)	3.3	1000	0.2	680	35	90	80
CK7805M-1000R3	24 (8 – 34)	5	1000	0.2	680	35	93	85
	12 (8 – 27)	-5	-500	1	330	35	85	81
CK7806M-1000R3	24 (10 – 34)	6.5	1000	0.2	680	35	93	85
CK7809M-1000R3	24 (13 – 34)	9	1000	0.2	680	35	94	89
CK7812M-1000R3	24 (15 – 34)	12	1000	0.2	680	35	95	92
	12 (8 – 20)	-12	-300	1	330	35	88	87
CK7815M-1000R3	24 (20 – 34)	15	1000	0.2	680	35	96	93
	12 (8 – 18)	-15	-300	1	330	35	88	87

Note: 1. “*” are models under developing.

2. When input voltage exceeds 30Vdc, the input terminal needs to be connected to an external 22μF/50V electrolytic capacitor to prevent module damage caused by voltage spikes.

Input Specifications

Item	Working Conditions	Min.	Typ.	Max.	Unit
No load input current	Positive output	--	0.2	1	mA
	Negative output	--	1	4	
Reverse Polarity at Input	--	Not allowed			
Input filter	--	Capacitor filter			

Output Specifications

Item	Working Conditions	Min.	Typ.	Max.	Unit	
Output Voltage Accuracy	Full load	--	±2	±3	%	
Ripple & Noise*	Nominal input, full load, 20MHZ bandwidth	--	35	75	mVp-p	
Load Regulation	Nominal input voltage, 10%~100% load	Positive output	--	±0.4	±0.6	%
		Negative output	--	±0.4	±0.8	
Line Regulation	Input Voltage Change	--	±0.2	±0.4		
Temperature Drift Coefficient	100% Load	--	--	±0.03	%/°C	
O/P Short Circuit Protection		Continuous, Self-recovery				

NOTE: *Ripple & Noise tested by twisted-pair method;

General Specifications

Switching Frequency	Typical	800KHz (Typ.)
Operating Temperature	Refer to Temperature Derating Curve	-40°C ~ +85°C
Storage Temperature		-55°C ~ +125°C
Shell temperature rise during work		100°C (MAX.)
Relative Humidity	No condensing	5%~95%
Case Material		Black flame-retardant heat-resistant Plastic (UL94 V-0)
Product Weight		2.0g (Typ.)
Pin Withstand Soldering Temp	Time,10S(Max)	260°C
MTBF	MIL-HDBK-217F@25°C	20X10 ⁵ Hrs
Package	Tube(525*18*10mm)	43PCS
	Carton(542*110*155mm)	3440pcs(total 80tubes)

Packing Dimension

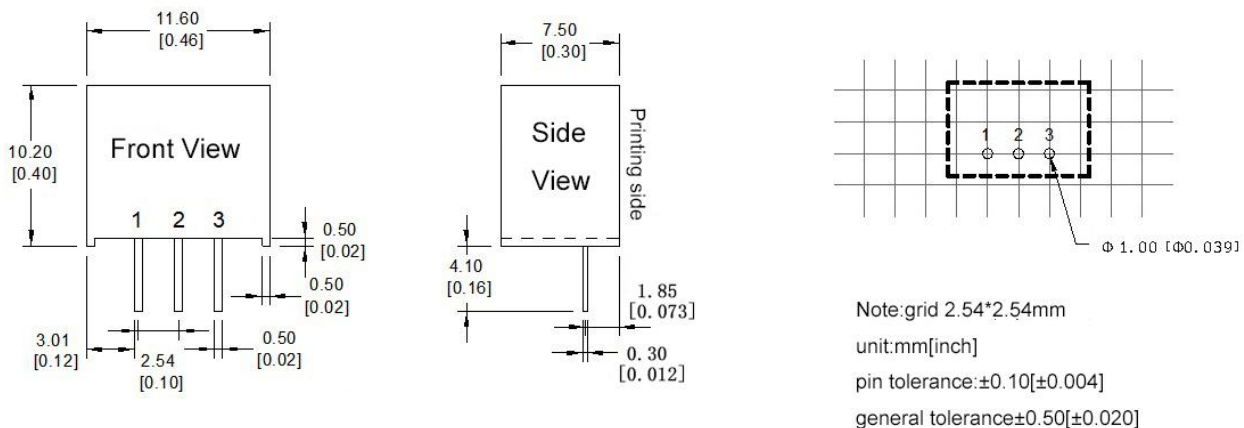

Packing Code	L x W x H	
CK78XXM-1000R3	11.60*7.50*10.20mm	0.457 × 0.295 × 0.402inch

Pin-Function

Pin-Out	1	2	3
Positive output	+Vin	GND	+Vo
Negative output	+Vin	-Vo	GND

Note: If the definition of pin is not in accordance with the manual, please refer to the label on actual item.

Ripple & Noise Test(Twisted pair method 20MHZ bandwidth)

Test Method:

a. 12# twisted pair to connect, Oscilloscope bandwidth set as 20MHz, 100M bandwidth probe, terminated with 0.1uF polypropylene capacitor and 10uF high frequency low resistance electrolytic capacitor in parallel, oscilloscope set as Sample pattern.

b. Input terminal connect to power supply, output terminal connect to electronic load through jig plate, Use 30cm±2 cm sampling line, Power line selected from corresponding diameter wire with insulation according to the flow of output current.

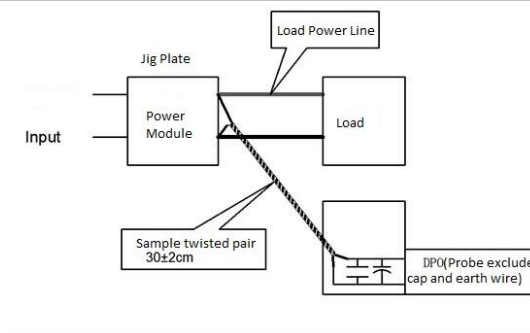

Characteristic Curve

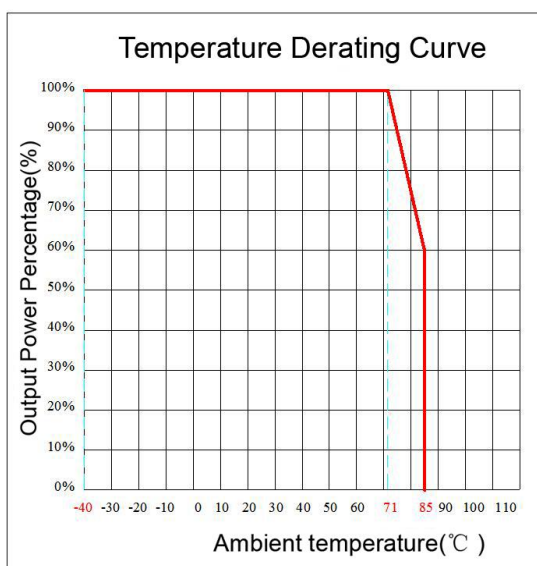

Design and Application Circuit Reference

1. Output Load Request

- a. To ensure this module operate efficiently and reliably, the minimum load could not be less than 10% of the nominal load. If the actual power is too small, please parallel a resistor at output terminal, the resistance equal to 10% of nominal load.
- b. The maximum capacitive load is tested under nominal input voltage with full load, and cannot exceed the maximum capacitive load of output side when using, or it will be difficult to start up and damage the product.

2. Recommended Circuit

In order to ensure the effective reduction of input and output ripple and noise, a capacitor filter network can be connected to the input

and output ends. The application circuit is shown in Photo 1 below; the negative output application circuit is shown in Photo 2 below, and the positive and negative output parallel application circuit is shown in Photo 3 below (Fig. The recommended value for LDM is 10μH), but a suitable filter capacitor should be selected. If the capacitor is too large, it may affect the startup of the product. To ensure that each output works under safe and reliable conditions, the recommended capacitive load values are detailed in Table 1 below. (Refer to the external capacitance table for the capacitance values of C1 and C2. You can increase the capacitance appropriately as needed. You can also use low-ESR tantalum capacitors and electrolytic capacitors.)

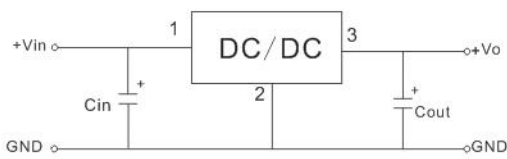

Positive output application circuit

Photo 1

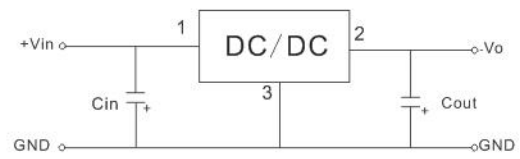

Negative output application circuit

Photo 2

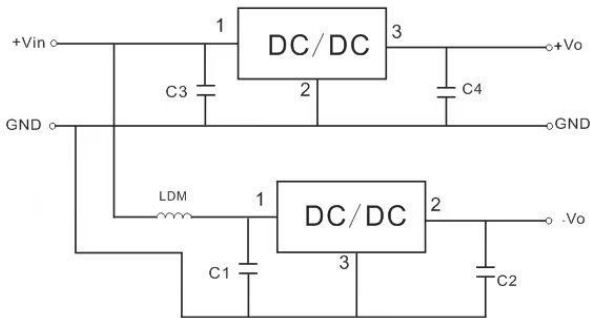

Parallel application circuit with positive and negative outputs

Photo 3

Recommended capacitive load value

Part No	C1/C3 ceramic capacitor	C2/C4 ceramic capacitor
CK7803M-1000R3	10 μF/50V	22 μF/10V
CK7805M-1000R3		22 μF/10V
CK7806M-1000R3		22 μF/16V
CK7809M-1000R3		22 μF/16V
CK7812M-1000R3		22 μF/25V
CK7815M-1000R3		22 μF/25V

Note:

- 1.This product cannot be used in parallel, and do not support hot-plugging;
- 2.All index testing methods in this datasheet are based on our Company's corporate standards
- 3.The product specification may be changed at any time without prior notice.